

CHAPTER 8

MULTIPLEXING

- 8.1 Frequency Division Multiplexing**
- 8.2 Synchronous Time Division Multiplexing**
- 8.3 Statistical Time Division Multiplexing**
- 8.4 Asymmetric Digital Subscriber Line**
- 8.5 xDSL**
- 8.6 Recommended Reading and Web Sites**
- 8.7 Key Terms, Review Questions, and Problems**

It was impossible to get a conversation going, everybody was talking too much.

Yogi Berra

KEY POINTS

- To make efficient use of high-speed telecommunications lines, some form of multiplexing is used. Multiplexing allows several transmission sources to share a larger transmission capacity. The two common forms of multiplexing are frequency division multiplexing (FDM) and time division multiplexing (TDM).
- **Frequency division multiplexing** can be used with analog signals. A number of signals are carried simultaneously on the same medium by allocating to each signal a different frequency band. Modulation equipment is needed to move each signal to the required frequency band, and multiplexing equipment is needed to combine the modulated signals.
- **Synchronous time division multiplexing** can be used with digital signals or analog signals carrying digital data. In this form of multiplexing, data from various sources are carried in repetitive frames. Each frame consists of a set of time slots, and each source is assigned one or more time slots per frame. The effect is to interleave bits of data from the various sources.
- **Statistical time division multiplexing** provides a generally more efficient service than synchronous TDM for the support of terminals. With statistical TDM, time slots are not preassigned to particular data sources. Rather, user data are buffered and transmitted as rapidly as possible using available time slots.

In Chapter 7, we described efficient techniques for utilizing a data link under heavy load. Specifically, with two devices connected by a point-to-point link, it is generally desirable to have multiple frames outstanding so that the data link does not become a bottleneck between the stations. Now consider the opposite problem. Typically, two communicating stations will not utilize the full capacity of a data link. For efficiency, it should be possible to share that capacity. A generic term for such sharing is **multiplexing**.

A common application of multiplexing is in long-haul communications. Trunks on long-haul networks are high-capacity fiber, coaxial, or microwave links. These links can carry large numbers of voice and data transmissions simultaneously using multiplexing.

Figure 8.1 depicts the multiplexing function in its simplest form. There are n inputs to a multiplexer. The multiplexer is connected by a single data link to a

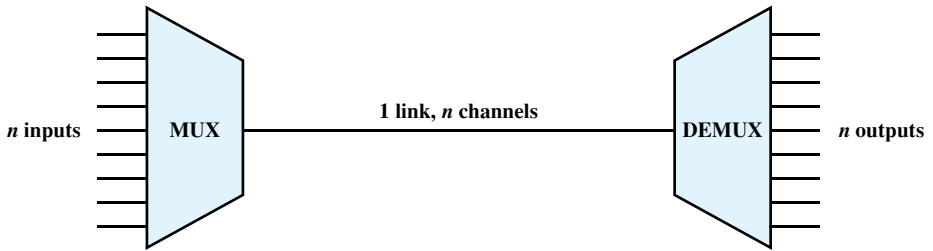

Figure 8.1 Multiplexing

demultiplexer. The link is able to carry n separate channels of data. The multiplexer combines (multiplexes) data from the n input lines and transmits over a higher-capacity data link. The demultiplexer accepts the multiplexed data stream, separates (demultiplexes) the data according to channel, and delivers data to the appropriate output lines.

The widespread use of multiplexing in data communications can be explained by the following:

- The higher the data rate, the more cost-effective the transmission facility. That is, for a given application and over a given distance, the cost per kbps declines with an increase in the data rate of the transmission facility. Similarly, the cost of transmission and receiving equipment, per kbps, declines with increasing data rate.
- Most individual data communicating devices require relatively modest data rate support. For example, for many terminal and personal computer applications that do not involve Web access or intensive graphics, a data rate of between 9600 bps and 64 kbps is generally adequate.

The preceding statements were phrased in terms of data communicating devices. Similar statements apply to voice communications. That is, the greater the capacity of a transmission facility, in terms of voice channels, the less the cost per individual voice channel, and the capacity required for a single voice channel is modest.

This chapter concentrates on three types of multiplexing techniques. The first, frequency division multiplexing (FDM), is the most heavily used and is familiar to anyone who has ever used a radio or television set. The second is a particular case of time division multiplexing (TDM) known as synchronous TDM. This is commonly used for multiplexing digitized voice streams and data streams. The third type seeks to improve on the efficiency of synchronous TDM by adding complexity to the multiplexer. It is known by a variety of names, including statistical TDM, asynchronous TDM, and intelligent TDM. This book uses the term *statistical TDM*, which highlights one of its chief properties. Finally, we look at the digital subscriber line, which combines FDM and synchronous TDM technologies.

8.1 FREQUENCY DIVISION MULTIPLEXING

Characteristics

FDM is possible when the useful bandwidth of the transmission medium exceeds the required bandwidth of signals to be transmitted. A number of signals can be carried simultaneously if each signal is modulated onto a different carrier frequency and the carrier frequencies are sufficiently separated that the bandwidths of the signals do not significantly overlap. A general case of FDM is shown in Figure 8.2a. Six signal

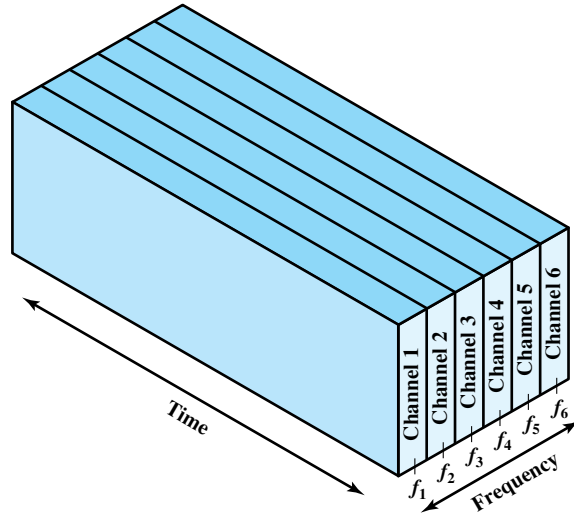

(a) Frequency division multiplexing

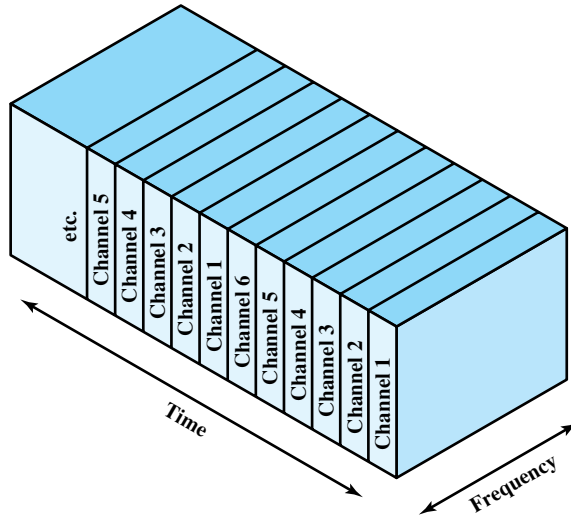

(b) Time division multiplexing

Figure 8.2 FDM and TDM

sources are fed into a multiplexer, which modulates each signal onto a different frequency (f_1, \dots, f_6). Each modulated signal requires a certain bandwidth centered on its carrier frequency, referred to as a **channel**. To prevent interference, the channels are separated by guard bands, which are unused portions of the spectrum.

The composite signal transmitted across the medium is analog. Note, however, that the input signals may be either digital or analog. In the case of digital input, the input signals must be passed through modems to be converted to analog. In either case, each input analog signal must then be modulated to move it to the appropriate frequency band.

EXAMPLE 8.1 A familiar example of FDM is broadcast and cable television. The television signal discussed in Chapter 3 fits comfortably into a 6-MHz bandwidth. Figure 8.3 depicts the transmitted TV signal and its bandwidth. The black-and-white video signal is AM modulated on a carrier signal f_{cv} . Because the baseband video signal has a bandwidth of 4 MHz, we would expect the modulated signal to have a bandwidth of 8 MHz centered on f_{cv} . To conserve bandwidth, the signal is passed through a sideband filter so that most of the lower sideband is suppressed. The resulting signal extends from about $f_{cv} - 0.75$ MHz to $f_{cv} + 4.2$ MHz. A separate color carrier, f_{cc} , is used to transmit color information. This is spaced far enough from f_{cv} that there is essentially no interference. Finally, the audio portion of the signal is modulated on f_{ca} , outside the effective bandwidth of the other two signals. A bandwidth of 50 kHz is allocated for the audio signal. The composite signal fits into a 6-MHz bandwidth with the video, color, and audio signal carriers at 1.25 MHz, 4.799545 MHz, and 5.75 MHz above the lower edge of the band, respectively. Thus, multiple TV signals can be frequency division multiplexed on a CATV cable, each with a bandwidth of 6 MHz. Given the enormous bandwidth of coaxial cable (as much as 500 MHz), dozens of TV signals can be simultaneously carried using FDM. Of course, using radio-frequency propagation through the atmosphere is also a form of FDM.

A generic depiction of an FDM system is shown in Figure 8.4. A number of analog or digital signals $[m_i(t), i = 1, n]$ are to be multiplexed onto the same transmission medium. Each signal $m_i(t)$ is modulated onto a carrier f_i ; because multiple carriers are to be used, each is referred to as a **subcarrier**. Any type of modulation may be used. The resulting analog, modulated signals are then summed to produce a composite baseband¹ signal $m_b(t)$. Figure 8.4b shows the result. The spectrum of signal $m_i(t)$ is shifted to be centered on f_i . For this scheme to work, f_i must be chosen so that the bandwidths of the various signals do not significantly overlap. Otherwise, it will be impossible to recover the original signals.

The composite signal may then be shifted as a whole to another carrier frequency by an additional modulation step. We will see examples of this later. This second modulation step need not use the same modulation technique as the first.

¹The term *baseband* is used to designate the band of frequencies of the signal delivered by the source and potentially used as a modulating signal. Typically, the spectrum of a baseband signal is significant in a band that includes or is in the vicinity of $f = 0$.

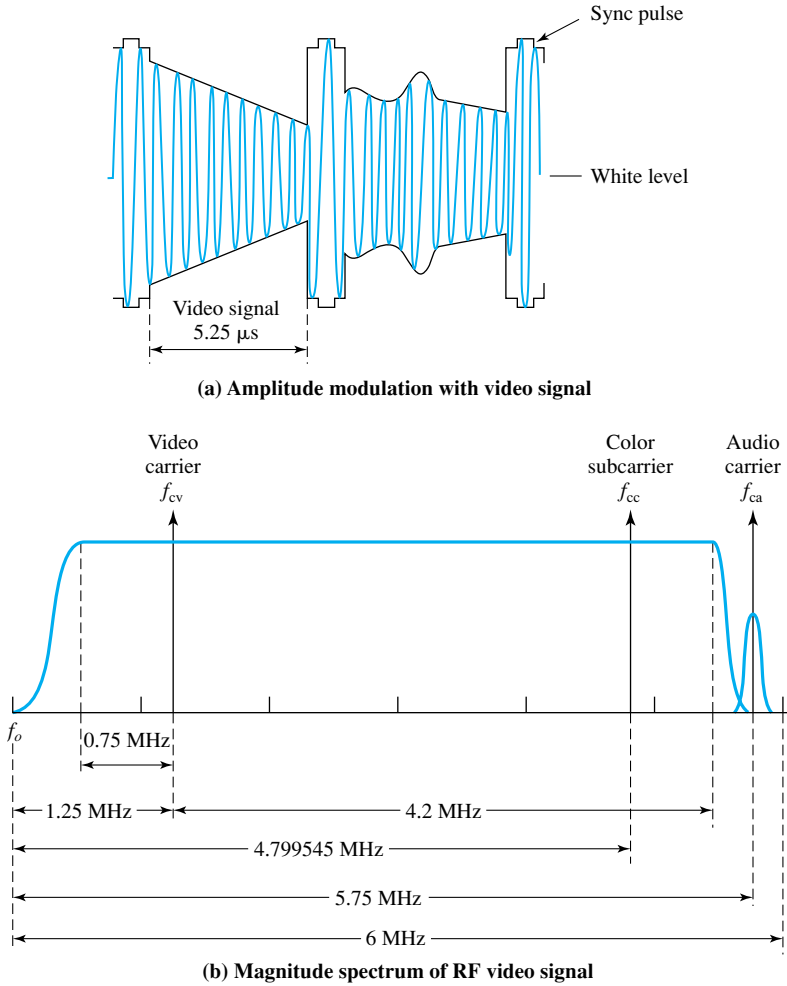

Figure 8.3 Transmitted TV Signal

The FDM signal $s(t)$ has a total bandwidth B , where $B > \sum_{i=1}^n B_i$. This analog signal may be transmitted over a suitable medium. At the receiving end, the FDM signal is demodulated to retrieve $m_b(t)$, which is then passed through n bandpass filters, each filter centered on f_i and having a bandwidth B_i , for $1 \leq i \leq n$. In this way, the signal is again split into its component parts. Each component is then demodulated to recover the original signal.

EXAMPLE 8.2 Let us consider a simple example of transmitting three voice signals simultaneously over a medium. As was mentioned, the bandwidth of a voice signal is generally taken to be 4 kHz, with an effective spectrum of 300 to 3400 Hz (Figure 8.5a). If such a signal is used to amplitude-modulate a 64-kHz carrier, the spectrum of Figure 8.5b results. The modulated signal has a bandwidth

of 8 kHz, extending from 60 to 68 kHz. To make efficient use of bandwidth, we elect to transmit only the lower sideband. If three voice signals are used to modulate carriers at 64, 68, and 72 kHz, and only the lower sideband of each is taken, the spectrum of Figure 8.5c results.

Figure 8.5 points out two problems that an FDM system must cope with. The first is crosstalk, which may occur if the spectra of adjacent component signals overlap significantly. In the case of voice signals, with an effective bandwidth of only 3100 Hz (300 to 3400), a 4-kHz bandwidth is adequate. The spectra of signals produced by modems for voiceband transmission also fit well in this bandwidth.

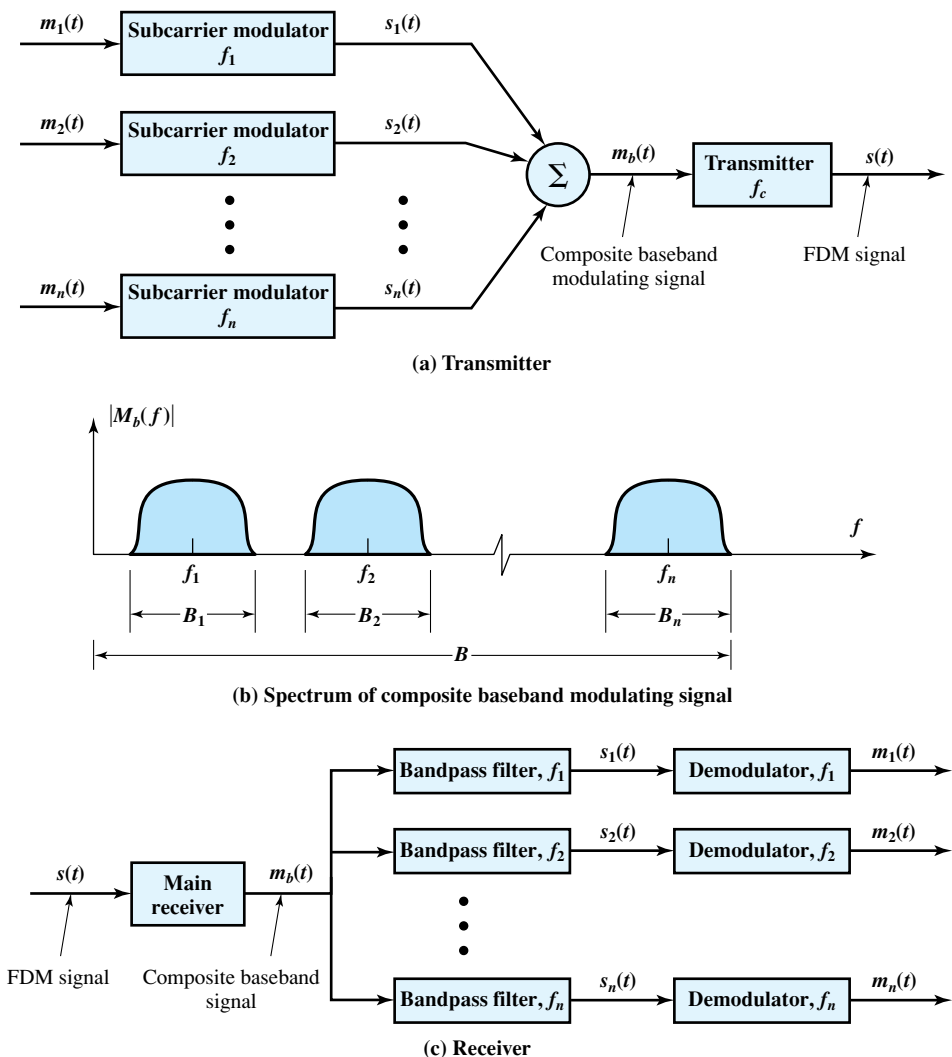

Figure 8.4 FDM System [COUC01]

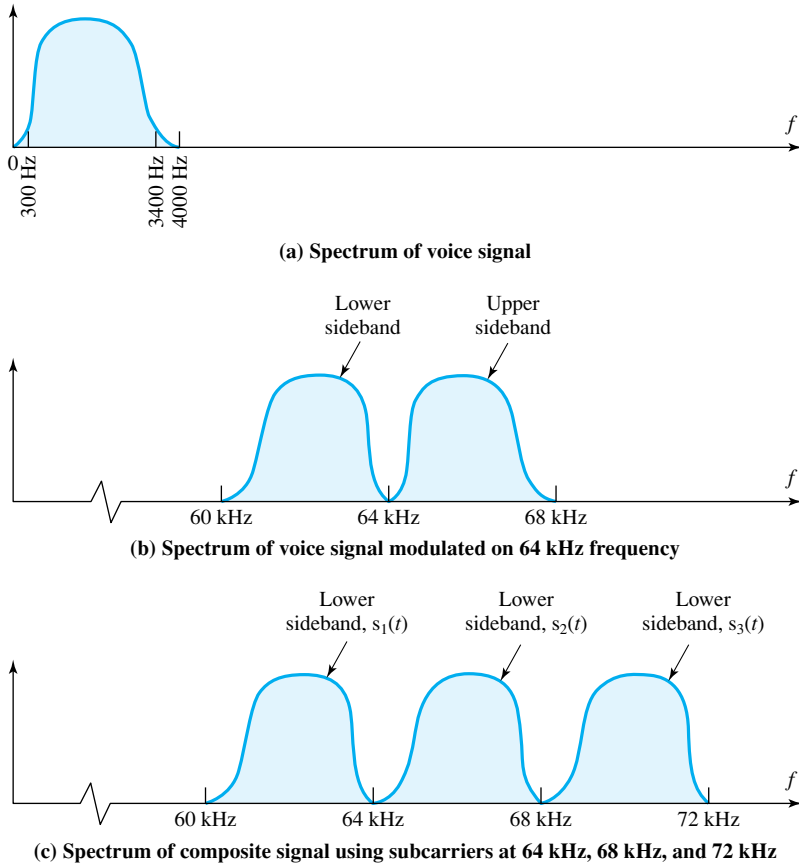

Figure 8.5 FDM of Three Voiceband Signals

Another potential problem is intermodulation noise, which was discussed in Chapter 3. On a long link, the nonlinear effects of amplifiers on a signal in one channel could produce frequency components in other channels.

Analog Carrier Systems

The long-distance carrier system provided in the United States and throughout the world is designed to transmit voiceband signals over high-capacity transmission links, such as coaxial cable and microwave systems. The earliest, and still a very common, technique for utilizing high-capacity links is FDM. In the United States, AT&T has designated a hierarchy of FDM schemes to accommodate transmission systems of various capacities. A similar, but unfortunately not identical, system has been adopted internationally under the auspices of ITU-T (Table 8.1).

At the first level of the AT&T hierarchy, 12 voice channels are combined to produce a group signal with a bandwidth of $12 \times 4 \text{ kHz} = 48 \text{ kHz}$, in the range 60 to 108 kHz. The signals are produced in a fashion similar to that described previously, using subcarrier frequencies of from 64 to 108 kHz in increments of 4 kHz.

Table 8.1 North American and International FDM Carrier Standards

Number of Voice Channels	Bandwidth	Spectrum	AT&T	ITU-T
12	48 kHz	60–108 kHz	Group	Group
60	240 kHz	312–552 kHz	Supergroup	Supergroup
300	1.232 MHz	812–2044 kHz		Mastergroup
600	2.52 MHz	564–3084 kHz	Mastergroup	
900	3.872 MHz	8.516–12.388 MHz		Supermaster group
$N \times 600$			Mastergroup multiplex	
3,600	16.984 MHz	0.564–17.548 MHz	Jumbogroup	
10,800	57.442 MHz	3.124–60.566 MHz	Jumbogroup multiplex	

The next basic building block is the 60-channel supergroup, which is formed by frequency division multiplexing five group signals. At this step, each group is treated as a single signal with a 48-kHz bandwidth and is modulated by a subcarrier. The subcarriers have frequencies from 420 to 612 kHz in increments of 48 kHz. The resulting signal occupies 312 to 552 kHz.

There are several variations to supergroup formation. Each of the five inputs to the supergroup multiplexer may be a group channel containing 12 multiplexed voice signals. In addition, any signal up to 48 kHz wide whose bandwidth is contained within 60 to 108 kHz may be used as input to the supergroup multiplexer. As another variation, it is possible to combine 60 voiceband channels into a supergroup. This may reduce multiplexing costs where an interface with existing group multiplexer is not required.

The next level of the hierarchy is the mastergroup, which combines 10 supergroup inputs. Again, any signal with a bandwidth of 240 kHz in the range 312 to 552 kHz can serve as input to the mastergroup multiplexer. The mastergroup has a bandwidth of 2.52 MHz and can support 600 voice frequency (VF) channels. Higher-level multiplexing is defined above the mastergroup, as shown in Table 8.1.

Note that the original voice or data signal may be modulated many times. For example, a data signal may be encoded using QPSK to form an analog voice signal. This signal could then be used to modulate a 76-kHz carrier to form a component of a group signal. This group signal could then be used to modulate a 516-kHz carrier to form a component of a supergroup signal. Each stage can distort the original data; this is so, for example, if the modulator/multiplexer contains nonlinearities or introduces noise.

Wavelength Division Multiplexing

The true potential of optical fiber is fully exploited when multiple beams of light at different frequencies are transmitted on the same fiber. This is a form of frequency division multiplexing (FDM) but is commonly called **wavelength division multiplexing (WDM)**. With WDM, the light streaming through the fiber consists of many colors, or wavelengths, each carrying a separate channel of data. In 1997, a landmark was reached when Bell Laboratories was able to demonstrate a WDM system with 100 beams each operating at 10 Gbps, for a total data rate of 1 trillion bits per second

Table 8.2 ITU WDM Channel Spacing (G.692)

Frequency (THz)	Wavelength in Vacuum (nm)	50 GHz	100 GHz	200 GHz
196.10	1528.77	X	X	X
196.05	1529.16	X		
196.00	1529.55	X	X	
195.95	1529.94	X		
195.90	1530.33	X	X	X
195.85	1530.72	X		
195.80	1531.12	X	X	
195.75	1531.51	X		
195.70	1531.90	X	X	X
195.65	1532.29	X		
195.60	1532.68	X	X	
...	...			
192.10	1560.61	X	X	X

(also referred to as 1 terabit per second or 1 Tbps). Commercial systems with 160 channels of 10 Gbps are now available. In a lab environment, Alcatel has carried 256 channels at 39.8 Gbps each, a total of 10.1 Tbps, over a 100-km span.

A typical WDM system has the same general architecture as other FDM systems. A number of sources generate a laser beam at different wavelengths. These are sent to a multiplexer, which consolidates the sources for transmission over a single fiber line. Optical amplifiers, typically spaced tens of kilometers apart, amplify all of the wavelengths simultaneously. Finally, the composite signal arrives at a demultiplexer, where the component channels are separated and sent to receivers at the destination point.

Most WDM systems operate in the 1550-nm range. In early systems, 200 GHz was allocated to each channel, but today most WDM systems use 50-GHz spacing. The channel spacing defined in ITU-T G.692, which accommodates 80 50-GHz channels, is summarized in Table 8.2.

The term **dense wavelength division multiplexing** (DWDM) is often seen in the literature. There is no official or standard definition of this term. The term connotes the use of more channels, more closely spaced, than ordinary WDM. In general, a channel spacing of 200 GHz or less could be considered dense.

8.2 SYNCHRONOUS TIME DIVISION MULTIPLEXING

Characteristics

Synchronous time division multiplexing is possible when the achievable data rate (sometimes, unfortunately, called bandwidth) of the medium exceeds the data rate of digital signals to be transmitted. Multiple digital signals (or analog signals carrying digital data) can be carried on a single transmission path by interleaving portions of each signal in time. The interleaving can be at the bit level or in blocks of

bytes or larger quantities. For example, the multiplexer in Figure 8.2b has six inputs that might each be, say, 9.6 kbps. A single line with a capacity of at least 57.6 kbps (plus overhead capacity) could accommodate all six sources.

A generic depiction of a synchronous TDM system is provided in Figure 8.6. A number of signals $[m_i(t), i = 1, n]$ are to be multiplexed onto the same transmission medium. The signals carry digital data and are generally digital signals. The incoming data from each source are briefly buffered. Each buffer is typically one bit or one character in length. The buffers are scanned sequentially to form a composite digital data stream $m_c(t)$. The scan operation is sufficiently rapid so that each buffer is emptied before more data can arrive. Thus, the data rate of $m_c(t)$ must at least equal the sum of the data rates of the $m_i(t)$. The digital signal $m_c(t)$ may be transmitted

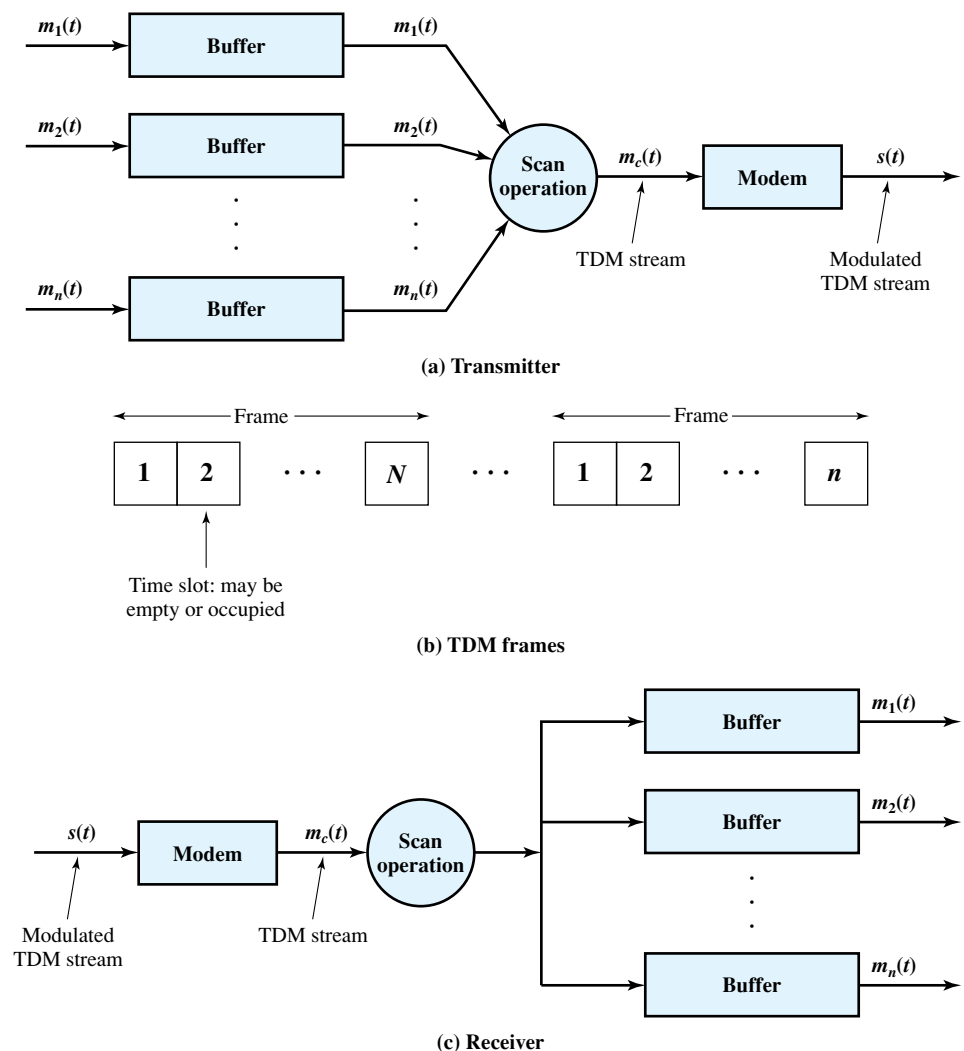

Figure 8.6 Synchronous TDM System

directly, or passed through a modem so that an analog signal is transmitted. In either case, transmission is typically synchronous.

The transmitted data may have a format something like Figure 8.6b. The data are organized into **frames**. Each frame contains a cycle of time slots. In each frame, one or more slots are dedicated to each data source. The sequence of slots dedicated to one source, from frame to frame, is called a **channel**. The slot length equals the transmitter buffer length, typically a bit or a byte (character).

The byte-interleaving technique is used with asynchronous and synchronous sources. Each time slot contains one character of data. Typically, the start and stop bits of each character are eliminated before transmission and reinserted by the receiver, thus improving efficiency. The bit-interleaving technique is used with synchronous sources and may also be used with asynchronous sources. Each time slot contains just one bit.

At the receiver, the interleaved data are demultiplexed and routed to the appropriate destination buffer. For each input source $m_i(t)$, there is an identical output destination that will receive the output data at the same rate at which it was generated.

Synchronous TDM is called synchronous not because synchronous transmission is used, but because the time slots are preassigned to sources and fixed. The time slots for each source are transmitted whether or not the source has data to send. This is, of course, also the case with FDM. In both cases, capacity is wasted to achieve simplicity of implementation. Even when fixed assignment is used, however, it is possible for a synchronous TDM device to handle sources of different data rates. For example, the slowest input device could be assigned one slot per cycle, while faster devices are assigned multiple slots per cycle.

TDM Link Control

The reader will note that the transmitted data stream depicted in Figure 8.6b does not contain the headers and trailers that we have come to associate with synchronous transmission. The reason is that the control mechanisms provided by a data link protocol are not needed. It is instructive to ponder this point, and we do so by considering two key data link control mechanisms: flow control and error control. It should be clear that, as far as the multiplexer and demultiplexer (Figure 8.1) are concerned, flow control is not needed. The data rate on the multiplexed line is fixed, and the multiplexer and demultiplexer are designed to operate at that rate. But suppose that one of the individual output lines attaches to a device that is temporarily unable to accept data. Should the transmission of TDM frames cease? Clearly not, because the remaining output lines are expecting to receive data at predetermined times. The solution is for the saturated output device to cause the flow of data from the corresponding input device to cease. Thus, for a while, the channel in question will carry empty slots, but the frames as a whole will maintain the same transmission rate.

The reasoning for error control is the same. It would not do to request retransmission of an entire TDM frame because an error occurs on one channel. The devices using the other channels do not want a retransmission nor would they know that a retransmission has been requested by some other device on another channel. Again, the solution is to apply error control on a per-channel basis.

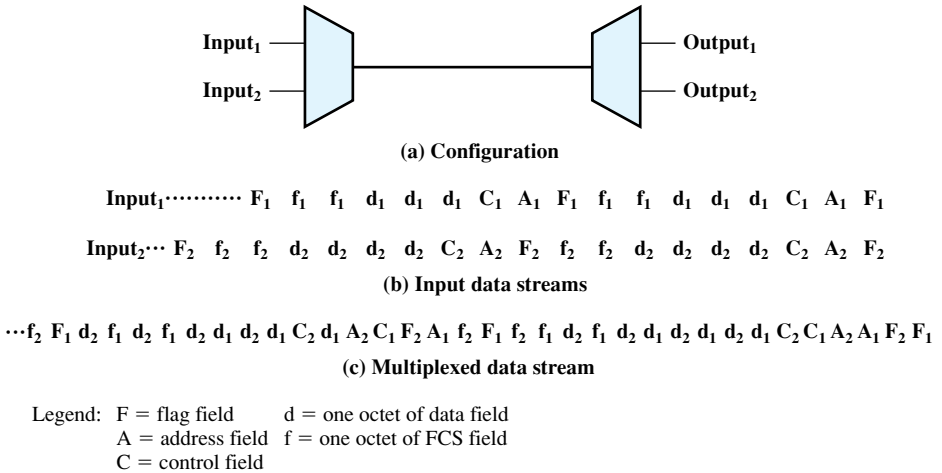

Figure 8.7 Use of Data Link Control on TDM Channels

Flow control and error control can be provided on a per-channel basis by using a data link control protocol such as HDLC on a per-channel basis. A simplified example is shown in Figure 8.7. We assume two data sources, each using HDLC. One is transmitting a stream of HDLC frames containing three octets of data each, and the other is transmitting HDLC frames containing four octets of data. For clarity, we assume that character-interleaved multiplexing is used, although bit interleaving is more typical. Notice what is happening. The octets of the HDLC frames from the two sources are shuffled together for transmission over the multiplexed line. The reader may initially be uncomfortable with this diagram, because the HDLC frames have lost their integrity in some sense. For example, each frame check sequence (FCS) on the line applies to a disjointed set of bits. Even the FCS is not in one piece. However, the pieces are reassembled correctly before they are seen by the device on the other end of the HDLC protocol. In this sense, the multiplexing/demultiplexing operation is transparent to the attached stations; to each communicating pair of stations, it appears that they have a dedicated link.

One refinement is needed in Figure 8.7. Both ends of the line need to be a combination multiplexer/demultiplexer with a full-duplex line in between. Then each channel consists of two sets of slots, one traveling in each direction. The individual devices attached at each end can, in pairs, use HDLC to control their own channel. The multiplexer/demultiplexers need not be concerned with these matters.

Framing We have seen that a link control protocol is not needed to manage the overall TDM link. There is, however, a basic requirement for framing. Because we are not providing flag or SYNC characters to bracket TDM frames, some means is needed to assure frame synchronization. It is clearly important to maintain framing synchronization because, if the source and destination are out of step, data on all channels are lost.

Perhaps the most common mechanism for framing is known as added-digit framing. In this scheme, typically, one control bit is added to each TDM frame. An identifiable pattern of bits, from frame to frame, is used as a “control channel.”

A typical example is the alternating bit pattern, 101010. . . This is a pattern unlikely to be sustained on a data channel. Thus, to synchronize, a receiver compares the incoming bits of one frame position to the expected pattern. If the pattern does not match, successive bit positions are searched until the pattern persists over multiple frames. Once framing synchronization is established, the receiver continues to monitor the framing bit channel. If the pattern breaks down, the receiver must again enter a framing search mode.

Pulse Stuffing Perhaps the most difficult problem in the design of a synchronous time division multiplexer is that of synchronizing the various data sources. If each source has a separate clock, any variation among clocks could cause loss of synchronization. Also, in some cases, the data rates of the input data streams are not related by a simple rational number. For both these problems, a technique known as pulse stuffing is an effective remedy. With pulse stuffing, the outgoing data rate of the multiplexer, excluding framing bits, is higher than the sum of the maximum instantaneous incoming rates. The extra capacity is used by stuffing extra dummy bits or pulses into each incoming signal until its rate is raised to that of a locally generated clock signal. The stuffed pulses are inserted at fixed locations in the multiplexer frame format so that they may be identified and removed at the demultiplexer.

EXAMPLE 8.3 An example, from [COUC01], illustrates the use of synchronous TDM to multiplex digital and analog sources (Figure 8.8). Consider that there are 11 sources to be multiplexed on a single link:

Source 1: Analog, 2-kHz bandwidth

Source 2: Analog, 4-kHz bandwidth

Source 3: Analog, 2-kHz bandwidth

Sources 4–11: Digital, 7200 bps synchronous

As a first step, the analog sources are converted to digital using PCM. Recall from Chapter 5 that PCM is based on the sampling theorem, which dictates that a signal be sampled at a rate equal to twice its bandwidth. Thus, the required sampling rate is 4000 samples per second for sources 1 and 3, and 8000 samples per second for source 2. These samples, which are analog (PAM), must then be quantized or digitized. Let us assume that 4 bits are used for each analog sample. For convenience, these three sources will be multiplexed first, as a unit. At a scan rate of 4 kHz, one PAM sample each is taken from sources 1 and 3, and two PAM samples are taken from source 2 per scan. These four samples are interleaved and converted to 4-bit PCM samples. Thus, a total of 16 bits is generated at a rate of 4000 times per second, for a composite bit rate of 64 kbps.

For the digital sources, pulse stuffing is used to raise each source to a rate of 8 kbps, for an aggregate data rate of 64 kbps. A frame can consist of multiple cycles of 32 bits, each containing 16 PCM bits and two bits from each of the eight digital sources.

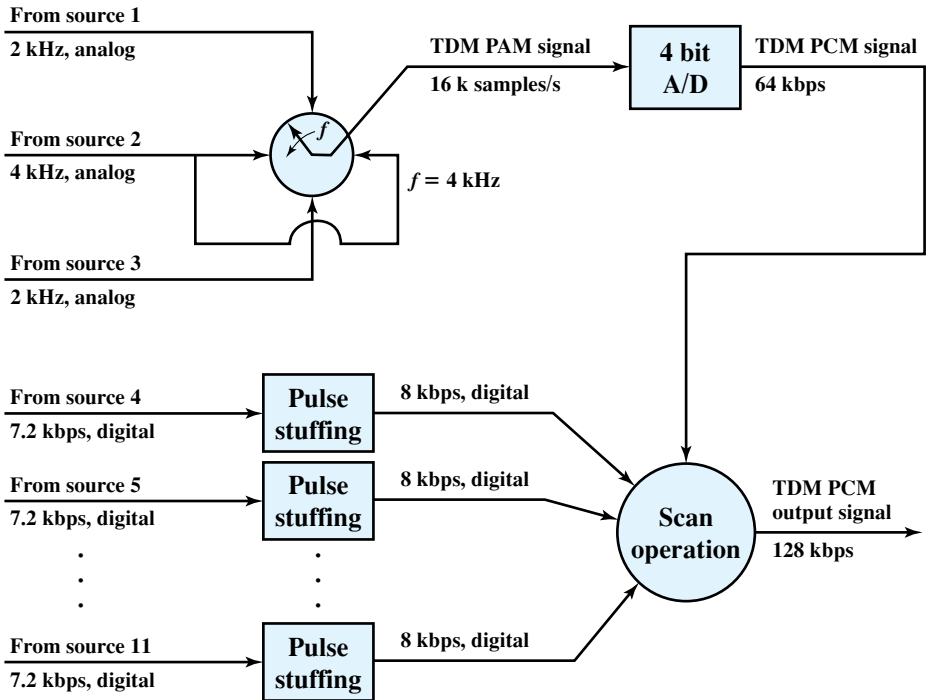

Figure 8.8 TDM of Analog and Digital Sources [COUC01]

Digital Carrier Systems

The long-distance carrier system provided in the United States and throughout the world was designed to transmit voice signals over high-capacity transmission links, such as optical fiber, coaxial cable, and microwave. Part of the evolution of these telecommunications networks to digital technology has been the adoption of synchronous TDM transmission structures. In the United States, AT&T developed a hierarchy of TDM structures of various capacities; this structure is used in Canada and Japan as well as the United States. A similar, but unfortunately not identical, hierarchy has been adopted internationally under the auspices of ITU-T (Table 8.3).

Table 8.3 North American and International TDM Carrier Standards

North American			International (ITU-T)		
Designation	Number of Voice Channels	Data Rate (Mbps)	Level	Number of Voice Channels	Data Rate (Mbps)
DS-1	24	1.544	1	30	2.048
DS-1C	48	3.152	2	120	8.448
DS-2	96	6.312	3	480	34.368
DS-3	672	44.736	4	1920	139.264
DS-4	4032	274.176	5	7680	565.148

The basis of the TDM hierarchy (in North America and Japan) is the DS-1 transmission format (Figure 8.9), which multiplexes 24 channels. Each frame contains 8 bits per channel plus a framing bit for $24 \times 8 + 1 = 193$ bits. For voice transmission, the following rules apply. Each channel contains one word of digitized voice data. The original analog voice signal is digitized using pulse code modulation (PCM) at a rate of 8000 samples per second. Therefore, each channel slot and hence each frame must repeat 8000 times per second. With a frame length of 193 bits, we have a data rate of $8000 \times 193 = 1.544$ Mbps. For five of every six frames, 8-bit PCM samples are used. For every sixth frame, each channel contains a 7-bit PCM word plus a *signaling bit*. The signaling bits form a stream for each voice channel that contains network control and routing information. For example, control signals are used to establish a connection or terminate a call.

The same DS-1 format is used to provide digital data service. For compatibility with voice, the same 1.544-Mbps data rate is used. In this case, 23 channels of data are provided. The twenty-fourth channel position is reserved for a special sync byte, which allows faster and more reliable reframing following a framing error. Within each channel, 7 bits per frame are used for data, with the eighth bit used to indicate whether the channel, for that frame, contains user data or system control data. With 7 bits per channel, and because each frame is repeated 8000 times per second, a data rate of 56 kbps can be provided per channel. Lower data rates are provided using a technique known as subrate multiplexing. For this technique, an additional bit is robbed from each channel to indicate which subrate multiplexing rate is being provided. This leaves a total capacity per channel of $6 \times 8000 = 48$ kbps. This capacity is used to multiplex five 9.6-kbps channels, ten 4.8-kbps channels, or twenty 2.4-kbps channels. For example, if channel 2 is used to provide 9.6-kbps service, then up to five data subchannels share this channel. The data for each subchannel appear as six bits in channel 2 every fifth frame.

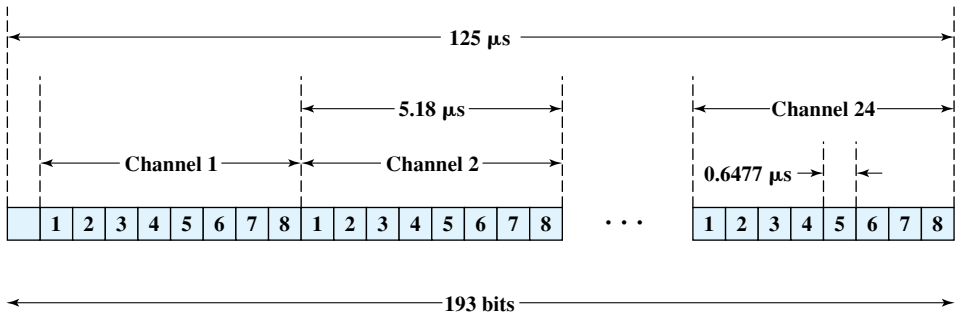

Notes:

1. The first bit is a framing bit, used for synchronization.
2. Voice channels:
 - 8-bit PCM used on five of six frames.
 - 7-bit PCM used on every sixth frame; bit 8 of each channel is a signaling bit.
3. Data channels:
 - Channel 24 is used for signaling only in some schemes.
 - Bits 1–7 used for 56-kbps service
 - Bits 2–7 used for 9.6-, 4.8-, and 2.4-kbps service.

Figure 8.9 DS-1 Transmission Format

Finally, the DS-1 format can be used to carry a mixture of voice and data channels. In this case, all 24 channels are utilized; no sync byte is provided.

Above the DS-1 data rate of 1.544 Mbps, higher-level multiplexing is achieved by interleaving bits from DS-1 inputs. For example, the DS-2 transmission system combines four DS-1 inputs into a 6.312-Mbps stream. Data from the four sources are interleaved 12 bits at a time. Note that $1.544 \times 4 = 6.176$ Mbps. The remaining capacity is used for framing and control bits.

SONET/SDH

SONET (Synchronous Optical Network) is an optical transmission interface originally proposed by BellCore and standardized by ANSI. A compatible version, referred to as Synchronous Digital Hierarchy (SDH), has been published by ITU-T in Recommendation G.707.² SONET is intended to provide a specification for taking advantage of the high-speed digital transmission capability of optical fiber.

Signal Hierarchy The SONET specification defines a hierarchy of standardized digital data rates (Table 8.4). The lowest level, referred to as STS-1 (Synchronous Transport Signal level 1) or OC-1 (Optical Carrier level 1),³ is 51.84 Mbps. This rate can be used to carry a single DS-3 signal or a group of lower-rate signals, such as DS1, DS1C, DS2, plus ITU-T rates (e.g., 2.048 Mbps).

Multiple STS-1 signals can be combined to form an STS-N signal. The signal is created by interleaving bytes from N STS-1 signals that are mutually synchronized.

For the ITU-T Synchronous Digital Hierarchy, the lowest rate is 155.52 Mbps, which is designated STM-1. This corresponds to SONET STS-3.

Table 8.4 SONET/SDH Signal Hierarchy

SONET Designation	ITU-T Designation	Data Rate	Payload Rate (Mbps)
STS-1/OC-1		51.84 Mbps	50.112 Mbps
STS-3/OC-3	STM-1	155.52 Mbps	150.336 Mbps
STS-9/OC-9		466.56 Mbps	451.008 Mbps
STS-12/OC-12	STM-4	622.08 Mbps	601.344 Mbps
STS-18/OC-18		933.12 Mbps	902.016 Mbps
STS-24/OC-24		1.24416 Gbps	1.202688 Gbps
STS-36/OC-36		1.86624 Gbps	1.804032 Gbps
STS-48/OC-48	STM-16	2.48832 Gbps	2.405376 Gbps
STS-96/OC-96		4.87664 Gbps	4.810752 Gbps
STS-192/OC-192	STM-64	9.95328 Gbps	9.621504 Gbps
STS-768	STM-256	39.81312 Gbps	38.486016 Gbps
STS-3072		159.25248 Gbps	153.944064 Gbps

²In what follows, we will use the term *SONET* to refer to both specifications. Where differences exist, these will be addressed.

³An OC- N rate is the optical equivalent of an STS- N electrical signal. End-user devices transmit and receive electrical signals; these must be converted to and from optical signals for transmission over optical fiber.

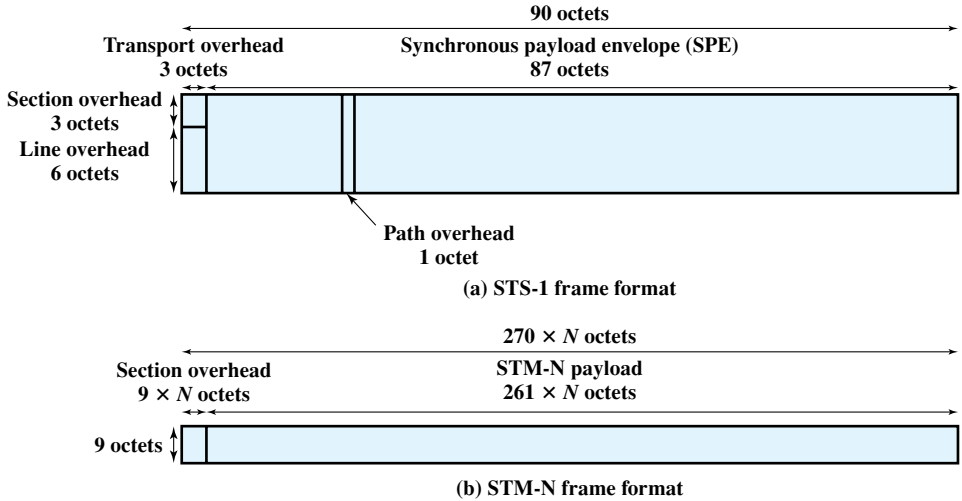

Figure 8.10 SONET/SDH Frame Formats

Frame Format The basic SONET building block is the STS-1 frame, which consists of 810 octets and is transmitted once every 125 μ s, for an overall data rate of 51.84 Mbps (Figure 8.10a). The frame can logically be viewed as a matrix of 9 rows of 90 octets each, with transmission being one row at a time, from left to right and top to bottom.

The first three columns (3 octets \times 9 rows = 27 octets) of the frame are devoted to overhead octets. Nine octets are devoted to section-related overhead

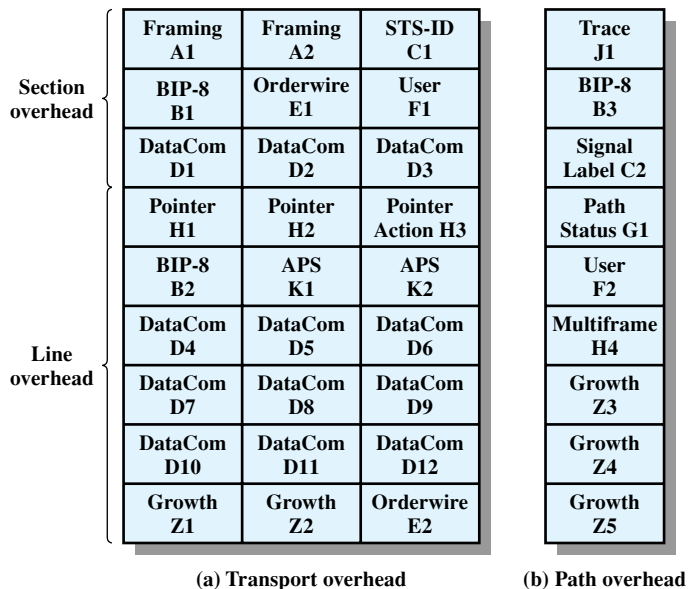

Figure 8.11 SONET STS-1 Overhead Octets

Table 8.5 STS-1 Overhead Bits

Section Overhead	
A1, A2:	Framing bytes = F6,28 hex; used to synchronize the beginning of the frame.
C1:	STS-1 ID identifies the STS-1 number (1 to N) for each STS-1 within an STS-N multiplex.
B1:	Bit-interleaved parity byte providing even parity over previous STS-N frame after scrambling; the <i>i</i> th bit of this octet contains the even parity value calculated from the <i>i</i> th bit position of all octets in the previous frame.
E1:	Section level 64-kbps PCM orderwire; optional 64-kbps voice channel to be used between section terminating equipment, hubs, and remote terminals.
F1:	64-kbps channel set aside for user purposes.
D1–D3:	192-kbps data communications channel for alarms, maintenance, control, and administration between sections.
Line Overhead	
H1–H3:	Pointer bytes used in frame alignment and frequency adjustment of payload data.
B2:	Bit-interleaved parity for line level error monitoring.
K1, K2:	Two bytes allocated for signaling between line level automatic protection switching equipment; uses a bit-oriented protocol that provides for error protection and management of the SONET optical link.
D4–D12:	576-kbps data communications channel for alarms, maintenance, control, monitoring, and administration at the line level.
Z1, Z2:	Reserved for future use.
E2:	64-kbps PCM voice channel for line level orderwire.
Path Overhead	
J1:	64-kbps channel used to send repetitively a 64-octet fixed-length string so a receiving terminal can continuously verify the integrity of a path; the contents of the message are user programmable.
B3:	Bit-interleaved parity at the path level, calculated over all bits of the previous SPE.
C2:	STS path signal label to designate equipped versus unequipped STS signals. <i>Unequipped</i> means the line connection is complete but there is no path data to send. For equipped signals, the label can indicate the specific STS payload mapping that might be needed in receiving terminals to interpret the payloads.
G1:	Status byte sent from path terminating equipment back to path originating equipment to convey status of terminating equipment and path error performance.
F2:	64-kbps channel for path user.
H4:	Multiframe indicator for payloads needing frames that are longer than a single STS frame; multiframe indicators are used when packing lower rate channels (virtual tributaries) into the SPE.
Z3–Z5:	Reserved for future use.

and 18 octets are devoted to line overhead. Figure 8.11a shows the arrangement of overhead octets, and Table 8.5 defines the various fields.

The remainder of the frame is payload. The payload includes a column of path overhead, which is not necessarily in the first available column position; the line overhead contains a pointer that indicates where the path overhead starts.

Figure 8.11b shows the arrangement of path overhead octets, and Table 8.5 defines these.

Figure 8.10b shows the general format for higher-rate frames, using the ITU-T designation.

8.3 STATISTICAL TIME DIVISION MULTIPLEXING

Characteristics

In a synchronous time division multiplexer, it is often the case that many of the time slots in a frame are wasted. A typical application of a synchronous TDM involves linking a number of terminals to a shared computer port. Even if all terminals are actively in use, most of the time there is no data transfer at any particular terminal.

An alternative to synchronous TDM is statistical TDM. The statistical multiplexer exploits this common property of data transmission by dynamically allocating time slots on demand. As with a synchronous TDM, the statistical multiplexer has a number of I/O lines on one side and a higher-speed multiplexed line on the other. Each I/O line has a buffer associated with it. In the case of the statistical multiplexer, there are n I/O lines, but only k , where $k < n$, time slots available on the TDM frame. For input, the function of the multiplexer is to scan the input buffers, collecting data until a frame is filled, and then send the frame. On output, the multiplexer receives a frame and distributes the slots of data to the appropriate output buffers.

Because statistical TDM takes advantage of the fact that the attached devices are not all transmitting all of the time, the data rate on the multiplexed line is less than the sum of the data rates of the attached devices. Thus, a statistical multiplexer can use a lower data rate to support as many devices as a synchronous multiplexer. Alternatively, if a statistical multiplexer and a synchronous multiplexer both use a link of the same data rate, the statistical multiplexer can support more devices.

Figure 8.12 contrasts statistical and synchronous TDM. The figure depicts four data sources and shows the data produced in four time epochs (t_0, t_1, t_2, t_3). In the case of the synchronous multiplexer, the multiplexer has an effective output rate of four times the data rate of any of the input devices. During each epoch, data are collected from all four sources and sent out. For example, in the first epoch, sources C and D produce no data. Thus, two of the four time slots transmitted by the multiplexer are empty.

In contrast, the statistical multiplexer does not send empty slots if there are data to send. Thus, during the first epoch, only slots for A and B are sent. However, the positional significance of the slots is lost in this scheme. It is not known ahead of time which source's data will be in any particular slot. Because data arrive from and are distributed to I/O lines unpredictably, address information is required to assure proper delivery. Thus, there is more overhead per slot for statistical TDM because each slot carries an address as well as data.

The frame structure used by a statistical multiplexer has an impact on performance. Clearly, it is desirable to minimize overhead bits to improve throughput. Typically, a statistical TDM system will use a synchronous protocol such as HDLC. Within the HDLC frame, the data frame must contain control bits for the multiplexing

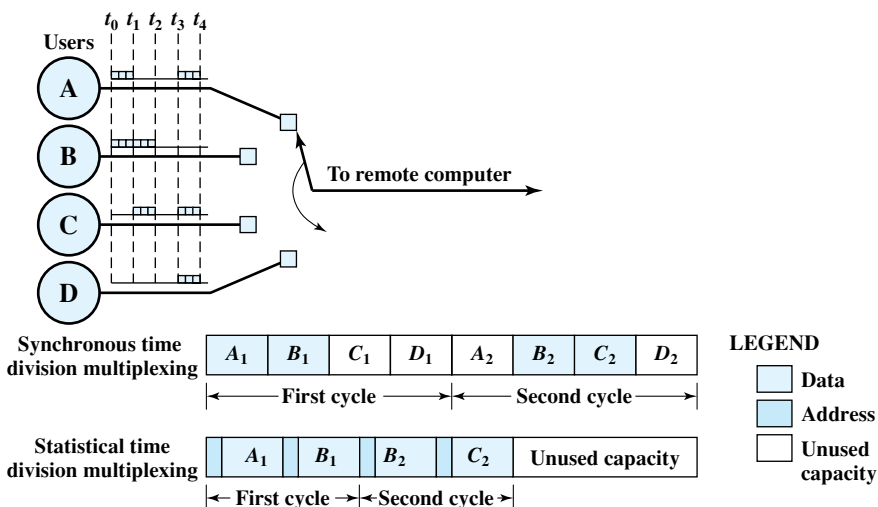

Figure 8.12 Synchronous TDM Compared with Statistical TDM

operation. Figure 8.13 shows two possible formats. In the first case, only one source of data is included per frame. That source is identified by an address. The length of the data field is variable, and its end is marked by the end of the overall frame. This scheme can work well under light load but is quite inefficient under heavy load.

A way to improve efficiency is to allow multiple data sources to be packaged in a single frame. Now, however, some means is needed to specify the length of data for each source. Thus, the statistical TDM subframe consists of a sequence of data fields, each labeled with an address and a length. Several techniques can be used to make this approach even more efficient. The address field can be reduced by using relative addressing. That is, each address specifies the number of the current source relative to the previous source, modulo the total number of sources. So, for example, instead of an 8-bit address field, a 4-bit field might suffice.



(a) Overall frame



(b) Subframe with one source per frame

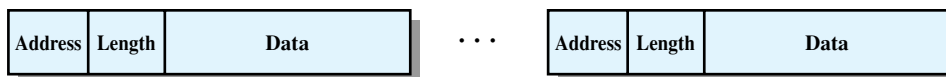

(c) Subframe with multiple sources per frame

Figure 8.13 Statistical TDM Frame Formats

Another refinement is to use a 2-bit label with the length field. A value of 00, 01, or 10 corresponds to a data field of 1, 2, or 3 bytes; no length field is necessary. A value of 11 indicates that a length field is included.

Yet another approach is to multiplex one character from each data source that has a character to send in a single data frame. In this case the frame begins with a bit map that has a bit length equal to the number of sources. For each source that transmits a character during a given frame, the corresponding bit is set to one.

Performance

We have said that the data rate of the output of a statistical multiplexer is less than the sum of the data rates of the inputs. This is allowable because it is anticipated that the average amount of input is less than the capacity of the multiplexed line. The difficulty with this approach is that, while the average aggregate input may be less than the multiplexed line capacity, there may be peak periods when the input exceeds capacity.

The solution to this problem is to include a buffer in the multiplexer to hold temporary excess input. Table 8.6 gives an example of the behavior of such systems. We assume 10 sources, each capable of 1000 bps, and we assume that the average

Table 8.6 Example of Statistical Multiplexer Performance

Input ^a	Capacity = 5000 bps		Capacity = 7000 bps	
	Output	Backlog	Output	Backlog
6	5	1	6	0
9	5	5	7	2
3	5	3	5	0
7	5	5	7	0
2	5	2	2	0
2	4	0	2	0
2	2	0	2	0
3	3	0	3	0
4	4	0	4	0
6	5	1	6	0
1	2	0	1	0
10	5	5	7	3
7	5	7	7	3
5	5	7	7	1
8	5	10	7	2
3	5	8	5	0
6	5	9	6	0
2	5	6	2	0
9	5	10	7	2
5	5	10	7	0

^aInput = 10 sources, 1000 bps/source; average input rate = 50% of maximum.

input per source is 50% of its maximum. Thus, on average, the input load is 5000 bps. Two cases are shown: multiplexers of output capacity 5000 bps and 7000 bps. The entries in the table show the number of bits input from the 10 devices each millisecond and the output from the multiplexer. When the input exceeds the output, backlog develops that must be buffered.

There is a tradeoff between the size of the buffer used and the data rate of the line. We would like to use the smallest possible buffer and the smallest possible data rate, but a reduction in one requires an increase in the other. Note that we are not so much concerned with the cost of the buffer—memory is cheap—as we are with the fact that the more buffering there is, the longer the delay. Thus, the tradeoff is really one between system response time and the speed of the multiplexed line. In this section, we present some approximate measures that examine this tradeoff. These are sufficient for most purposes.

Let us define the following parameters for a statistical time division multiplexer:

I = number of input sources

R = data rate of each source, bps

M = effective capacity of multiplexed line, bps

α = mean fraction of time each source is transmitting, $0 < \alpha < 1$

$K = \frac{M}{IR}$ = ratio of multiplexed line capacity to total maximum input

We have defined M taking into account the overhead bits introduced by the multiplexer. That is, M represents the maximum rate at which data bits can be transmitted.

The parameter K is a measure of the compression achieved by the multiplexer. For example, for a given data rate M , if $K = 0.25$, there are four times as many devices being handled as by a synchronous time division multiplexer using the same link capacity. The value of K can be bounded:

$$\alpha < K < 1$$

A value of $K = 1$ corresponds to a synchronous time division multiplexer, because the system has the capacity to service all input devices at the same time. If $K < \alpha$, the input will exceed the multiplexer's capacity.

Some results can be obtained by viewing the multiplexer as a single-server queue. A queuing situation arises when a "customer" arrives at a service facility and, finding it busy, is forced to wait. The delay incurred by a customer is the time spent waiting in the queue plus the time for the service. The delay depends on the pattern of arriving traffic and the characteristics of the server. Table 8.7 summarizes results for the case of random (Poisson) arrivals and constant service time. For details, see Appendix I. This model is easily related to the statistical multiplexer:

$$\lambda = \alpha IR$$

$$T_s = \frac{1}{M}$$

Table 8.7 Single-Server Queues with Constant Service Times and Poisson (Random) Arrivals

Parameters
λ = mean number of arrivals per second
T_s = service time for each arrival
ρ = utilization; fraction of time server is busy
N = mean number of items in system (waiting and being served)
T_r = residence time; mean time an item spends in system (waiting and being served)
σ_r = standard deviation of T_r
Formulas
$\rho = \lambda T_s$
$N = \frac{\rho^2}{2(1 - \rho)} + \rho$
$T_r = \frac{T_s(2 - \rho)}{2(1 - \rho)}$
$\sigma_r = \frac{1}{1 - \rho} \sqrt{\rho - \frac{3\rho^2}{2} + \frac{5\rho^3}{6} - \frac{\rho^4}{12}}$

The average arrival rate λ , in bps, is the total potential input (IR) times the fraction of time α that each source is transmitting. The service time T_s , in seconds, is the time it takes to transmit one bit, which is $1/M$. Note that

$$\rho = \lambda T_s = \frac{\alpha IR}{M} = \frac{\alpha}{K} = \frac{\lambda}{M}$$

The parameter ρ is the utilization or fraction of total link capacity being used. For example, if the capacity M is 50 kbps and $\rho = 0.5$, the load on the system is 25 kbps. The parameter N in Table 8.7 is a measure of the amount of buffer space being used in the multiplexer. Finally, T_r is a measure of the average delay encountered by an input source.

Figure 8.14 gives some insight into the nature of the tradeoff between system response time and the speed of the multiplexed line. It assumes that data are being transmitted in 1000-bit frames. Figure 8.14a shows the average number of frames that must be buffered as a function of the average utilization of the multiplexed line. The utilization is expressed as a percentage of the total line capacity. Thus, if the average input load is 5000 bps, the utilization is 100% for a line capacity of 5000 bps and about 71% for a line capacity of 7000 bps. Figure 8.14b shows the average delay experienced by a frame as a function of utilization and data rate. Note that as the utilization rises, so do the buffer requirements and the delay. A utilization above 80% is clearly undesirable.

Note that the average buffer size being used depends only on ρ , and not directly on M . For example, consider the following two cases:

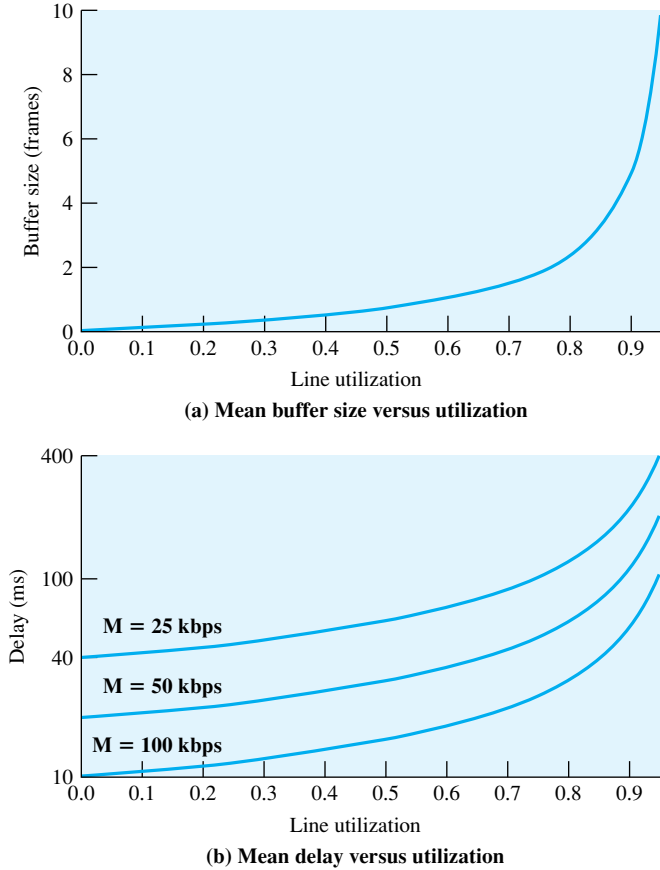

Figure 8.14 Buffer Size and Delay for a Statistical Multiplexer

Case I	Case II
$I = 10$	$I = 100$
$R = 100$ bps	$R = 100$ bps
$\alpha = 0.4$	$\alpha = 0.4$
$M = 500$ bps	$M = 5000$ bps

In both cases, the value of ρ is 0.8 and the mean buffer size is $N = 2.4$. Thus, proportionately, a smaller amount of buffer space per source is needed for multiplexers that handle a larger number of sources. Figure 8.14b also shows that the average delay will be smaller as the link capacity increases, for constant utilization.

So far, we have been considering average queue length, and hence the average amount of buffer capacity needed. Of course, there will be some fixed upper bound on the buffer size available. The variance of the queue size grows with utilization. Thus, at a higher level of utilization, a larger buffer is needed to hold the backlog. Even so, there is always a finite probability that the buffer will overflow. Figure 8.15

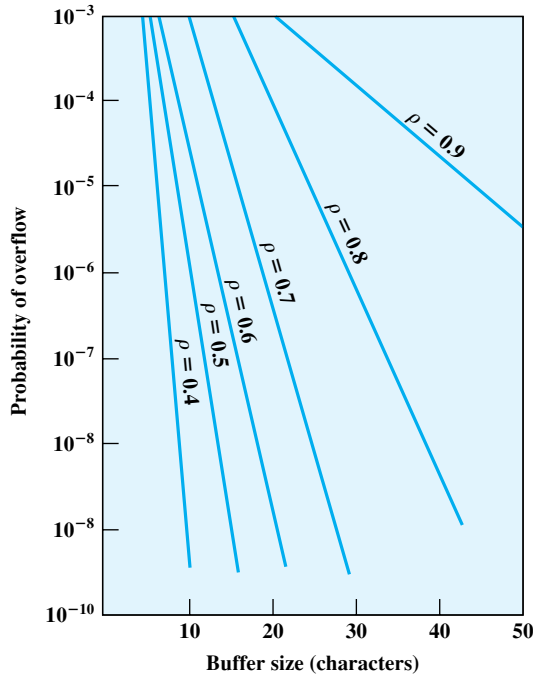

Figure 8.15 Probability of Overflow as a Function of Buffer Size

shows the strong dependence of overflow probability on utilization. This figure and Figure 8.14, suggest that utilization above about 0.8 is undesirable.

Cable Modem

To support data transfer to and from a cable modem, a cable TV provider dedicates two channels, one for transmission in each direction. Each channel is shared by a number of subscribers, and so some scheme is needed for allocating capacity on each channel for transmission. Typically, a form of statistical TDM is used, as illustrated in Figure 8.16. In the downstream direction, cable **headend** to subscriber, a cable scheduler delivers data in the form of small packets. Because the channel is shared by a number of subscribers, if more than one subscriber is active, each subscriber gets only a fraction of the downstream capacity. An individual cable modem subscriber may experience access speeds from 500 kbps to 1.5 Mbps or more, depending on the network architecture and traffic load. The downstream direction is also used to grant time slots to subscribers. When a subscriber has data to transmit, it must first request time slots on the shared upstream channel. Each subscriber is given dedicated time slots for this request purpose. The headend scheduler responds to a request packet by sending back an assignment of future time slots to be used by this subscriber. Thus, a number of subscribers can share the same upstream channel without conflict.

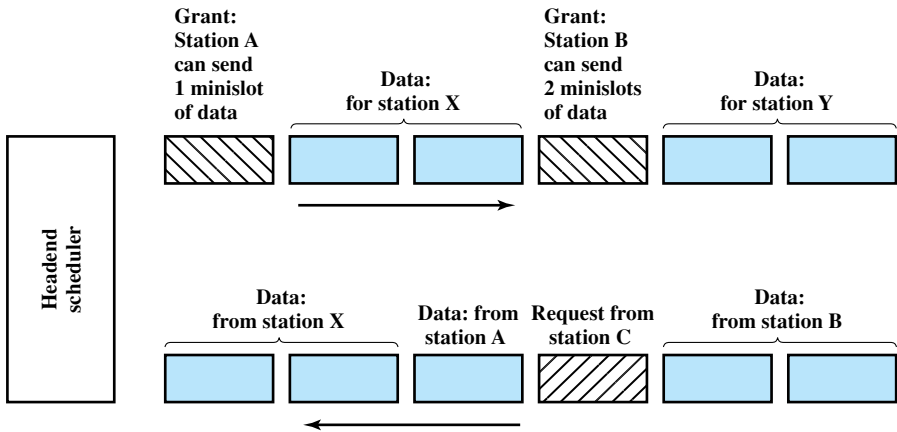

Figure 8.16 Cable Modem Scheme [DUTT99]

8.4 ASYMMETRIC DIGITAL SUBSCRIBER LINE

In the implementation and deployment of a high-speed wide area public digital network, the most challenging part is the link between subscriber and network: the digital subscriber line. With billions of potential endpoints worldwide, the prospect of installing new cable for each new customer is daunting. Instead, network designers have sought ways of exploiting the installed base of twisted-pair wire that links virtually all residential and business customers to telephone networks. These links were installed to carry voice-grade signals in a bandwidth from zero to 4 kHz. However, the wires are capable of transmitting signals over a far broader spectrum—1 MHz or more.

ADSL is the most widely publicized of a family of new modem technologies designed to provide high-speed digital data transmission over ordinary telephone wire. ADSL is now being offered by a number of carriers and is defined in an ANSI standard. In this section, we first look at the overall design of ADSL and then examine the key underlying technology, known as DMT.

ADSL Design

The term *asymmetric* refers to the fact that ADSL provides more capacity downstream (from the carrier's central office to the customer's site) than upstream (from customer to carrier). ADSL was originally targeted at the expected need for video on demand and related services. This application has not materialized. However, since the introduction of ADSL technology, the demand for high-speed access to the Internet has grown. Typically, the user requires far higher capacity for downstream than for upstream transmission. Most user transmissions are in the form of keyboard strokes or transmission of short e-mail messages, whereas incoming traffic, especially Web traffic, can involve large amounts of data and include images or even video. Thus, ADSL provides a perfect fit for the Internet requirement.

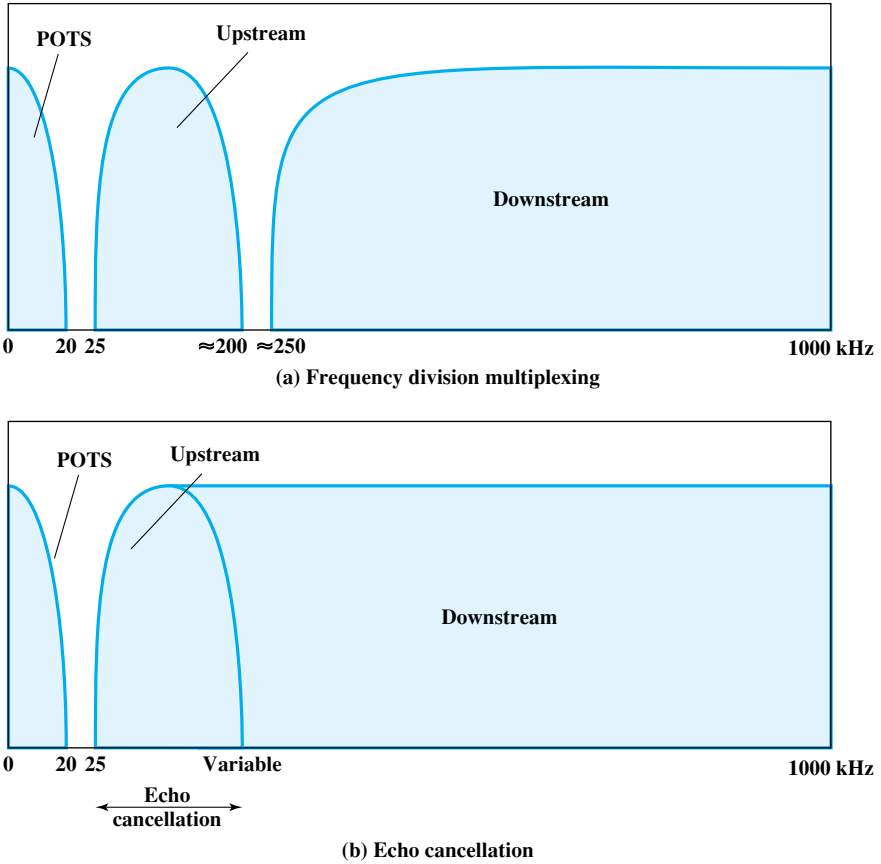

Figure 8.17 ADSL Channel Configuration

ADSL uses frequency division multiplexing (FDM) in a novel way to exploit the 1-MHz capacity of twisted pair. There are three elements of the ADSL strategy (Figure 8.17):

- Reserve lowest 25 kHz for voice, known as POTS (plain old telephone service). The voice is carried only in the 0 to 4 kHz band; the additional bandwidth is to prevent crosstalk between the voice and data channels.
- Use either echo cancellation⁴ or FDM to allocate two bands, a smaller upstream band and a larger downstream band.
- Use FDM within the upstream and downstream bands. In this case, a single bit stream is split into multiple parallel bit streams and each portion is carried in a separate frequency band.

⁴Echo cancellation is a signal processing technique that allows transmission of digital signals in both directions on a single transmission line simultaneously. In essence, a transmitter must subtract the echo of its own transmission from the incoming signal to recover the signal sent by the other side.

When echo cancellation is used, the entire frequency band for the upstream channel overlaps the lower portion of the downstream channel. This has two advantages compared to the use of distinct frequency bands for upstream and downstream.

- The higher the frequency, the greater the attenuation. With the use of echo cancellation, more of the downstream bandwidth is in the “good” part of the spectrum.
- The echo cancellation design is more flexible for changing upstream capacity. The upstream channel can be extended upward without running into the downstream; instead, the area of overlap is extended.

The disadvantage of the use of echo cancellation is the need for echo cancellation logic on both ends of the line.

The ADSL scheme provides a range of up to 5.5 km, depending on the diameter of the cable and its quality. This is sufficient to cover about 95% of all U.S. subscriber lines and should provide comparable coverage in other nations.

Discrete Multitone

Discrete multitone (DMT) uses multiple carrier signals at different frequencies, sending some of the bits on each channel. The available transmission band (upstream or downstream) is divided into a number of 4-kHz subchannels. On initialization, the DMT modem sends out test signals on each subchannel to determine the signal-to-noise ratio. The modem then assigns more bits to channels with better signal transmission qualities and less bits to channels with poorer signal transmission qualities. Figure 8.18 illustrates this process. Each subchannel can carry a data rate of from 0 to 60 kbps. The figure shows a typical situation in which there is increasing attenuation and hence decreasing signal-to-noise ratio at higher frequencies. As a result, the higher-frequency subchannels carry less of the load.

Figure 8.19 provides a general block diagram for DMT transmission. After initialization, the bit stream to be transmitted is divided into a number of substreams, one for each subchannel that will carry data. The sum of the data rates of the substreams is equal to the total data rate. Each substream is then converted to an analog signal using quadrature amplitude modulation (QAM), described in Chapter 5. This scheme works easily because of QAM’s ability to assign different numbers of bits per transmitted signal. Each QAM signal occupies a distinct frequency band, so these signals can be combined by simple addition to produce the composite signal for transmission.

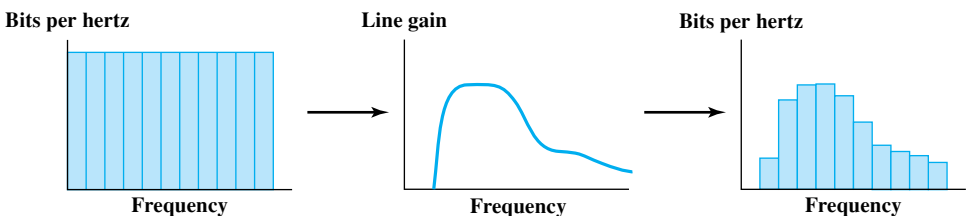

Figure 8.18 DMT Bits per Channel Allocation

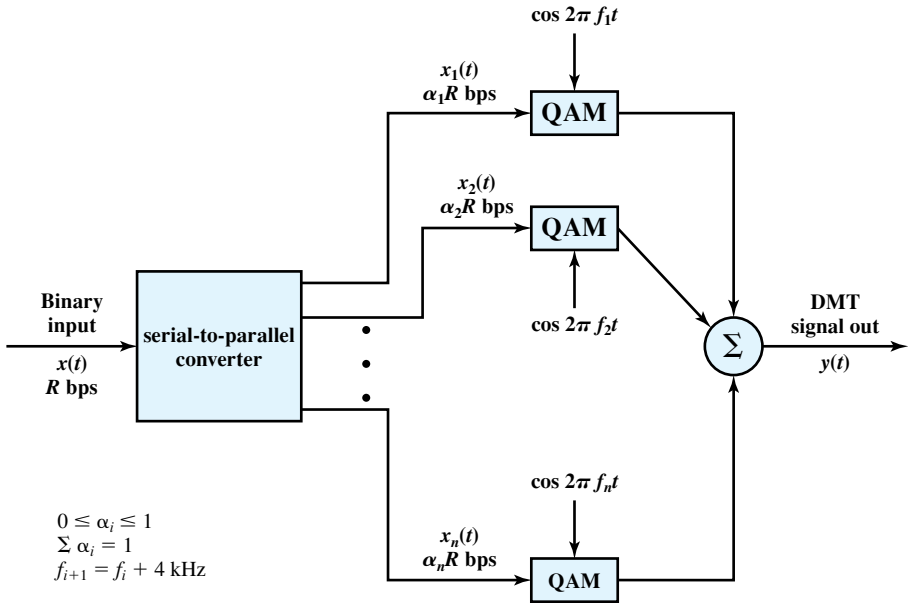

Figure 8.19 DMT Transmitter

Present ADSL/DMT designs employ 256 downstream subchannels. In theory, with each 4-kHz subchannel carrying 60 kbps, it would be possible to transmit at a rate of 15.36 Mbps. In practice, transmission impairments prevent attainment of this data rate. Current implementations operate at from 1.5 to 9 Mbps, depending on line distance and quality.

8.5 xDSL

ADSL is one of a number of recent schemes for providing high-speed digital transmission of the subscriber line. Table 8.8 summarizes and compares some of the most important of these new schemes, which collectively are referred to as xDSL.

High Data Rate Digital Subscriber Line

HDSL was developed in the late 1980s by BellCore to provide a more cost-effective means of delivering a T1 data rate (1.544 Mbps). The standard T1 line uses alternate mark inversion (AMI) coding, which occupies a bandwidth of about 1.5 MHz. Because such high frequencies are involved, the attenuation characteristics limit the use of T1 to a distance of about 1 km between repeaters. Thus, for many subscriber lines one or more repeaters are required, which adds to the installation and maintenance expense.

HDSL uses the 2B1Q coding scheme to provide a data rate of up to 2 Mbps over two twisted-pair lines within a bandwidth that extends only up to about 196 kHz. This enables a range of about 3.7 km to be achieved.

Table 8.8 Comparison of xDSL Alternatives

	ADSL	HDSL	SDSL	VDSL
Data rate	1.5 to 9 Mbps downstream 16 to 640 kbps upstream	1.544 or 2.048 Mbps	1.544 or 2.048 Mbps	13 to 52 Mbps downstream 1.5 to 2.3 Mbps upstream
Mode	Asymmetric	Symmetric	Symmetric	Asymmetric
Copper pairs	1	2	1	1
Range (24-gauge UTP)	3.7 to 5.5 km	3.7 km	3.0 km	1.4 km
Signaling	Analog	Digital	Digital	Analog
Line code	CAP/DMT	2B1Q	2B1Q	DMT
Frequency	1 to 5 MHz	196 kHz	196 kHz	≥ 10 MHz
Bits/cycle	Varies	4	4	Varies

UTP = unshielded twisted pair

Single Line Digital Subscriber Line

Although HDSL is attractive for replacing existing T1 lines, it is not suitable for residential subscribers because it requires two twisted pair, whereas the typical residential subscriber has a single twisted pair. SDSL was developed to provide the same type of service as HDSL but over a single twisted-pair line. As with HDSL, 2B1Q coding is used. Echo cancellation is used to achieve full-duplex transmission over a single pair.

Very High Data Rate Digital Subscriber Line

One of the newest xDSL schemes is VDSL. As of this writing, many of the details of this signaling specification remain to be worked out. The objective is to provide a scheme similar to ADSL at a much higher data rate by sacrificing distance. The likely signaling technique is DMT/QAM.

VDSL does not use echo cancellation but provides separate bands for different services, with the following tentative allocation:

- POTS: 0–4 kHz
- ISDN: 4–80 kHz
- Upstream: 300–700 kHz
- Downstream: ≥ 1 MHz

8.6 RECOMMENDED READING AND WEB SITES

A discussion of FDM and TDM carrier systems can be found in [FREE98] and [CARN99]. SONET is treated in greater depth in [STAL99] and in [TEKT01]. Useful articles on SONET are [BALL89] and [BOEH90]. A good overview of WDM is [MUKH00].

Two good articles on cable modems are [FELL01] and [CICI01].

[MAXW96] provides a useful a discussion of ADSL. Recommended treatments of xDSL are [HAWL97] and [HUMP97].

BALL89 Ballart, R., and Ching, Y. "SONET: Now It's the Standard Optical Network." *IEEE Communications Magazine*, March 1989.

BOEH90 Boehm, R. "Progress in Standardization of SONET." *IEEE LCS*, May 1990.

CARN99 Carne, E. *Telecommunications Primer: Data, Voice, and Video Communications*. Upper Saddle River, NJ: Prentice Hall, 1999.

CICI01 Ciciora, W. "The Cable Modem." *IEEE Spectrum*, June 2001.

FELL01 Fellows, D., and Jones, D. "DOCSIS Cable Modem Technology." *IEEE Communications Magazine*, March 2001.

FREE98 Freeman, R. *Telecommunications Transmission Handbook*. New York: Wiley, 1998.

HAWL97 Hawley, G. "Systems Considerations for the Use of xDSL Technology for Data Access." *IEEE Communications Magazine*, March 1997.

HUMP97 Humphrey, M., and Freeman, J. "How xDSL Supports Broadband Services to the Home." *IEEE Network*, January/March 1997.

MAXW96 Maxwell, K. "Asymmetric Digital Subscriber Line: Interim Technology for the Next Forty Years." *IEEE Communications Magazine*, October 1996.

MUKH00 Mukherjee, B. "WDM Optical Communication Networks: Progress and Challenges." *IEEE Journal on Selected Areas in Communications*, October 2000.

STAL99 Stallings, W. *ISDN and Broadband ISDN, with Frame Relay and ATM*. Upper Saddle River, NJ: Prentice Hall, 1999.

TEKT01 Tektronix. *SONET Telecommunications Standard Primer*. Tektronix White Paper, 2001, www.tektronix.com/optical.

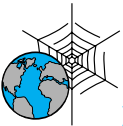

Recommended Web sites:

- **DSL Forum:** Includes a FAQ and technical information about ADSL and other xDSL technologies
- **Network and Services Integration Forum:** Discusses current products, technology, and standards
- **SONET Home Page:** Useful links, tutorials, white papers, FAQs

8.7 KEY TERMS, REVIEW QUESTIONS, AND PROBLEMS

Key Terms

ADSL baseband cable modem channel demultiplexer	dense WDM digital carrier system discrete multitone downstream echo cancellation	frame frequency division multiplexing (FDM) multiplexer multiplexing
---	--	--

pulse stuffing SDH SONET statistical TDM	subcarrier synchronous TDM time division multiplexing (TDM)	upstream wavelength division multiplexing (WDM)
---	--	---

Review Questions

- 8.1. Why is multiplexing so cost-effective?
- 8.2. How is interference avoided by using frequency division multiplexing?
- 8.3. What is echo cancellation?
- 8.4. Define *upstream* and *downstream* with respect to subscriber lines.
- 8.5. Explain how synchronous time division multiplexing (TDM) works.
- 8.6. Why is a statistical time division multiplexer more efficient than a synchronous time division multiplexer?
- 8.7. Using Table 8.3 as a guide, indicate the major difference between North American and international TDM carrier standards.
- 8.8. Using Figure 8.14 as a guide, indicate the relationship between buffer size and line utilization.

Problems

- 8.1. The information in four analog signals is to be multiplexed and transmitted over a telephone channel that has a 400- to 3100-Hz bandpass. Each of the analog baseband signals is bandlimited to 500 Hz. Design a communication system (block diagram) that will allow the transmission of these four sources over the telephone channel using
 - a. Frequency division multiplexing with SSB (single sideband) subcarriers
 - b. Time division multiplexing using PCM; assume 4-bit samples
 Show the block diagrams of the complete system, including the transmission, channel, and reception portions. Include the bandwidths of the signals at the various points in the systems.
- 8.2. To paraphrase Lincoln: . . . all of the channel some of the time, some of the channel all of the time. . . . Refer to Figure 8.2 and relate the preceding to the figure.
- 8.3. Consider a transmission system using frequency division multiplexing. What cost factors are involved in adding one more pair of stations to the system?
- 8.4. In synchronous TDM, it is possible to interleave bits, one bit from each channel participating in a cycle. If the channel is using a self-clocking code to assist synchronization, might this bit interleaving introduce problems because there is not a continuous stream of bits from one source?
- 8.5. Why is it that the start and stop bits can be eliminated when character interleaving is used in synchronous TDM?
- 8.6. Explain in terms of data link control and physical layer concepts how error and flow control are accomplished in synchronous time division multiplexing.
- 8.7. One of the 193 bits in the DS-1 transmission format is used for frame synchronization. Explain its use.
- 8.8. In the DS-1 format, what is the control signal data rate for each voice channel?
- 8.9. Twenty-four voice signals are to be multiplexed and transmitted over twisted pair. What is the bandwidth required for FDM? Assuming a bandwidth efficiency (ratio of

data rate to transmission bandwidth, as explained in Chapter 5) of 1 bps/Hz, what is the bandwidth required for TDM using PCM?

- 8.10** Draw a block diagram similar to Figure 8.8 for a TDM PCM system that will accommodate four 300-bps, synchronous, digital inputs and one analog input with a bandwidth of 500 Hz. Assume that the analog samples will be encoded into 4-bit PCM words.
- 8.11** A character-interleaved time division multiplexer is used to combine the data streams of a number of 110-bps asynchronous terminals for data transmission over a 2400-bps digital line. Each terminal sends asynchronous characters consisting of 7 data bits, 1 parity bit, 1 start bit, and 2 stop bits. Assume that one synchronization character is sent every 19 data characters and, in addition, at least 3% of the line capacity is reserved for pulse stuffing to accommodate speed variations from the various terminals.
- Determine the number of bits per character.
 - Determine the number of terminals that can be accommodated by the multiplexer.
 - Sketch a possible framing pattern for the multiplexer.
- 8.12** Find the number of the following devices that could be accommodated by a T1-type TDM line if 1% of the T1 line capacity is reserved for synchronization purposes.
- 110-bps teleprinter terminals
 - 300-bps computer terminals
 - 1200-bps computer terminals
 - 9600-bps computer output ports
 - 64-kbps PCM voice-frequency lines

How would these numbers change if each of the sources were transmitting an average of 10% of the time and a statistical multiplexer was used?

- 8.13** Ten 9600-bps lines are to be multiplexed using TDM. Ignoring overhead bits in the TDM frame, what is the total capacity required for synchronous TDM? Assuming that we wish to limit average TDM link utilization to 0.8, and assuming that each TDM link is busy 50% of the time, what is the capacity required for statistical TDM?
- 8.14** A synchronous nonstatistical TDM is to be used to combine four 4.8-kbps and one 9.6-kbps signals for transmission over a single leased line. For framing, a block of 7 bits (pattern 1011101) is inserted for each 48 data bits. The reframing algorithm (at the receiving demultiplex) is as follows:
- Arbitrarily select a bit position.
 - Consider the block of 7 contiguous bits starting with that position.
 - Observe that block of 7 bits each frame for 12 consecutive frames.
 - If 10 of the 12 blocks match the framing pattern the system is “in-frame”; if not advance one bit position and return to step 2.
 - Draw the multiplexed bit stream (note that the 9.6kbps input may be treated as two 4.8-kbps inputs).
 - What is the % overhead in the multiplexed bit stream?
 - What is the multiplexed output bit rate?
 - What is the minimum reframe time? What is the maximum reframe time? What is the Average reframe time?
- 8.15** A company has two locations: a headquarters and a factory about 25 km away. The factory has four 300-bps terminals that communicate with the central computer facilities over leased voice-grade lines. The company is considering installing TDM equipment so that only one line will be needed. What cost factors should be considered in the decision?
- 8.16** In synchronous TDM, the I/O lines serviced by the two multiplexers may be either synchronous or asynchronous although the channel between the two multiplexers must be synchronous. Is there any inconsistency in this? Why or why not?
- 8.17** Assume that you are to design a TDM carrier, say DS-489, to support 30 voice channels using 6-bit samples and a structure similar to DS-1. Determine the required bit rate.

8.18 For a statistical time division multiplexer, define the following parameters:

F = frame length, bits

OH = overhead in a frame, bits

L = load of data in the frame, bps

C = capacity of link, bps

- a.** Express F as a function of the other parameters. Explain why F can be viewed as a variable rather than a constant.
 - b.** Plot F versus L for $C = 9.6$ kbps and values of $OH = 40, 80, 120$. Comment on the results and compare to Figure 8.14.
 - c.** Plot F versus L for $OH = 40$ and values of $C = 9.6$ kbps and 8.2 kbps. Comment on the results and compare to Figure 8.14.
- 8.19** In statistical TDM, there may be a length field. What alternative could there be to the inclusion of a length field? What problem might this solution cause and how could it be solved?