

Bahan Ajar

Chapter 2



Materi Pembelajaran

Matakuliah :

WIRELESS SENSOR NETWORKS

Kode Matakuliah : SKO 20428

Prodi : **SISTEM KOMPUTER**

Dosen Pengampu Matakuliah:

Bayu Nugroho, S.Kom., M.Eng

Tables of Content

Electromagnetic Wave Propagation

Path loss of radio signals

Blocking or shadowing of radio signals

Scattering and diffraction of waves

Multiplexing

Tugas Mandiri



Electromagnetic Wave Propagation

In wireless networks, the signal has no wire to determine the direction of propagation, whereas signals in wired networks only travel along the wire.

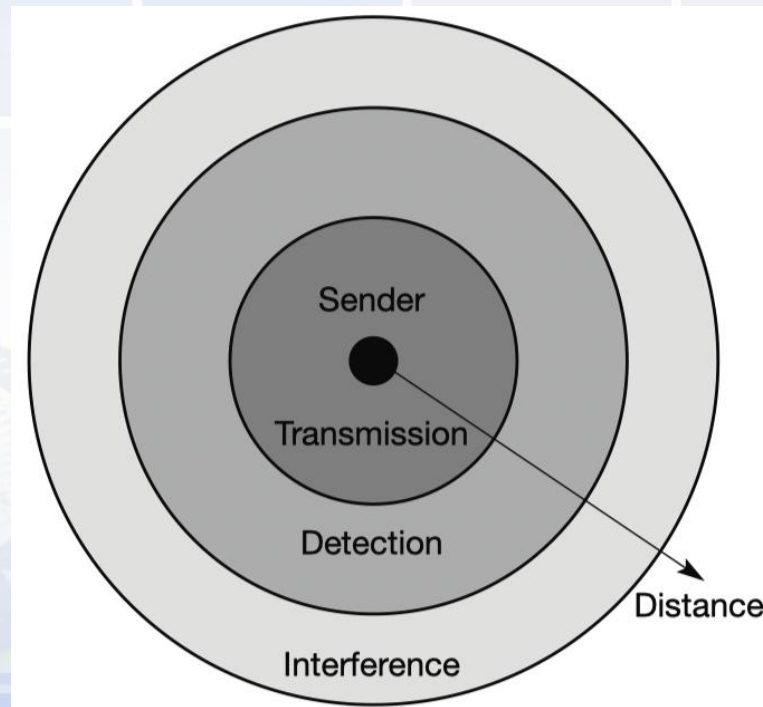

Path loss of radio signals

Radio waves can exhibit three fundamental propagation behaviors depending on their frequency:

Ground wave (<2 MHz): Waves with low frequencies follow the earth's surface and can propagate long distances. These waves are used for, e.g., submarine communication or AM radio.

Path loss of radio signals

Sky wave (2–30 MHz): This way the waves can bounce back and forth between the ionosphere and the earth's surface, travelling around the world.

Line-of-sight (>30 MHz): Mobile phone systems, satellite systems, cordless telephones etc. use even higher frequencies. The emitted waves follow a (more or less) straight line of sight. This enables direct communication with satellites (no reflection at the ionosphere) or microwave links on the ground.

Blocking or shadowing of radio signals

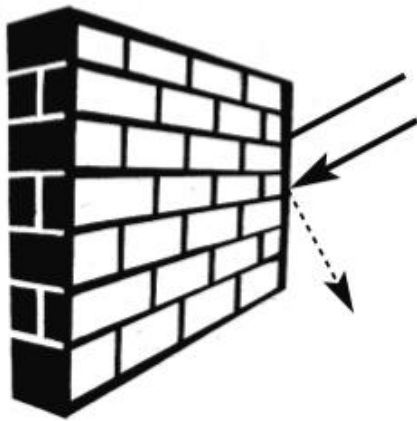

Shadowing

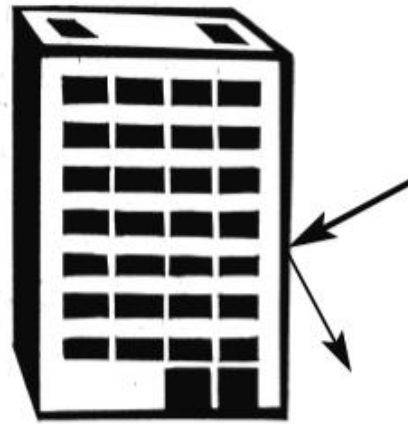

Reflection

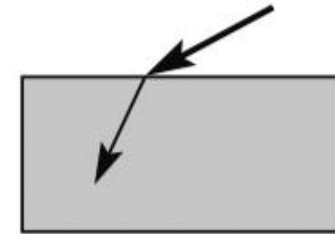

Refraction



Chapter 2

Scattering and diffraction of waves

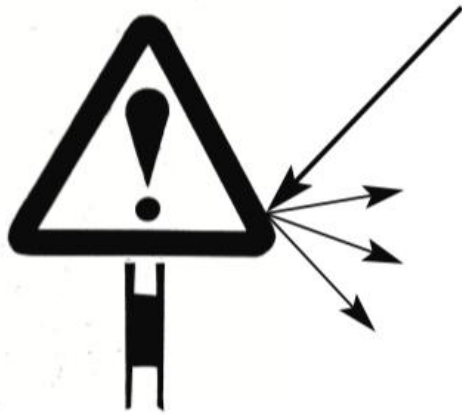

Scattering



Diffraction



Chapter 2

Multi-path propagation

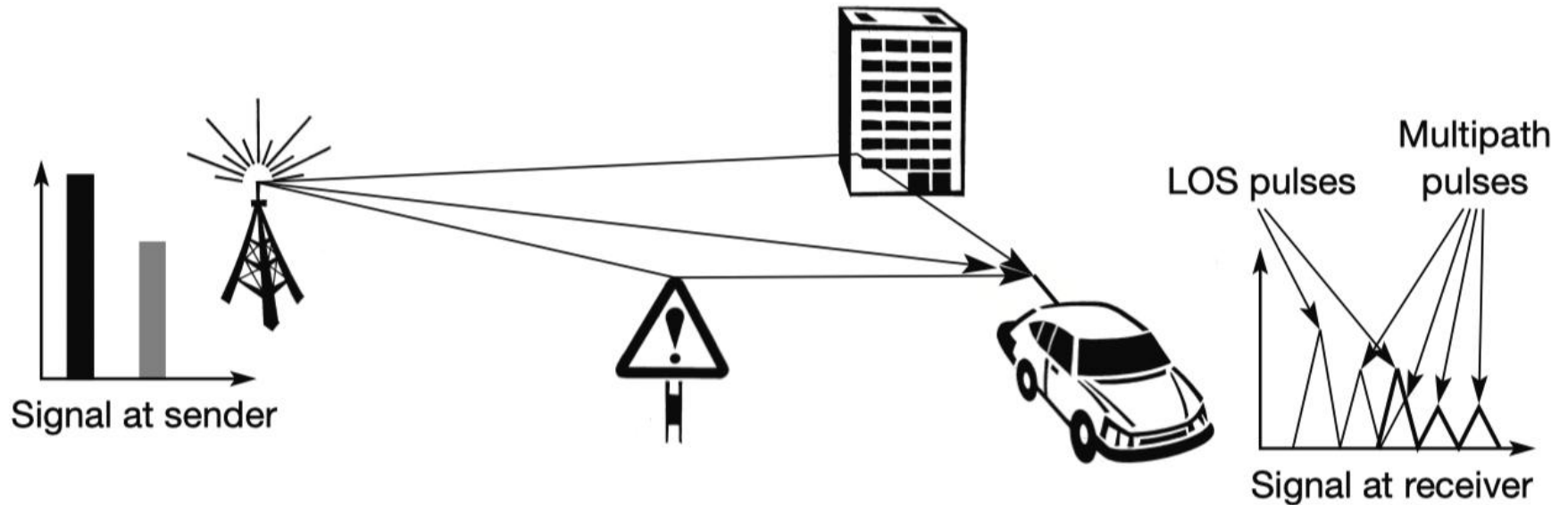

Chapter 2

Multiplexing

Space division multiplexing

Channels k_i

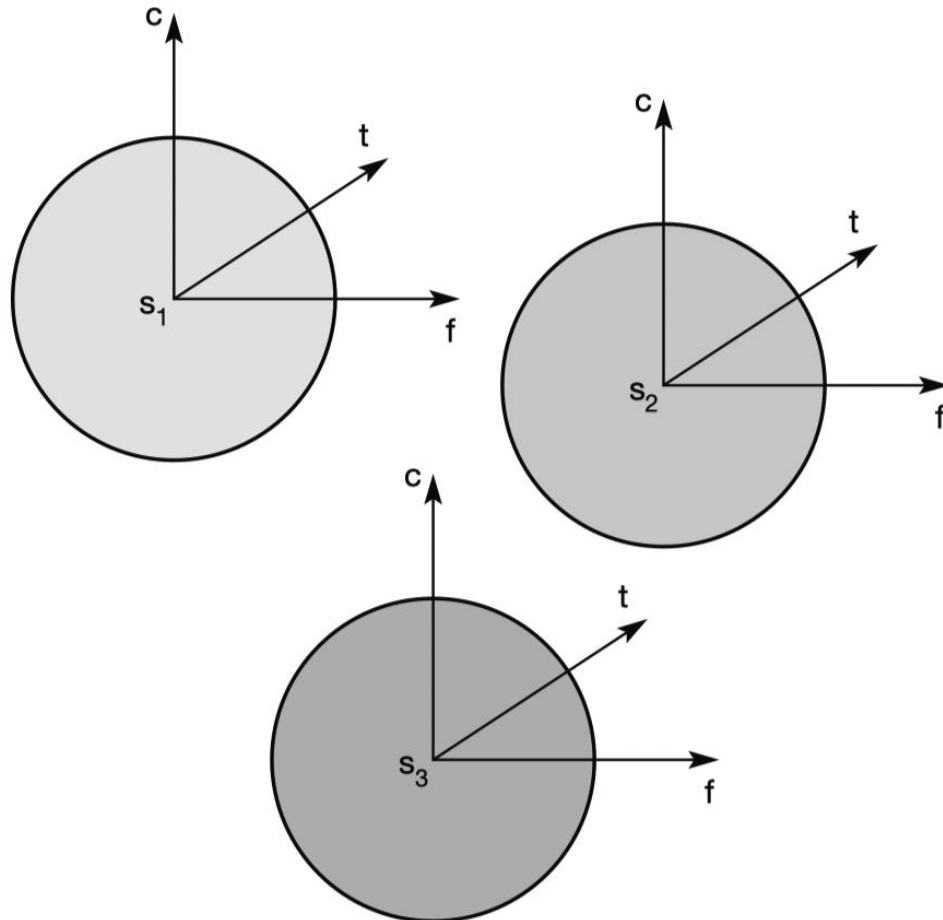
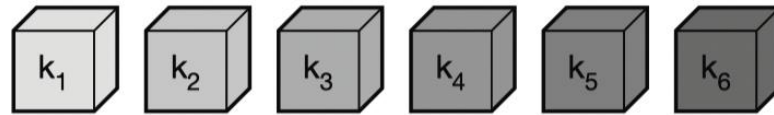

Multiplexing

Frequency
division
multiplexing

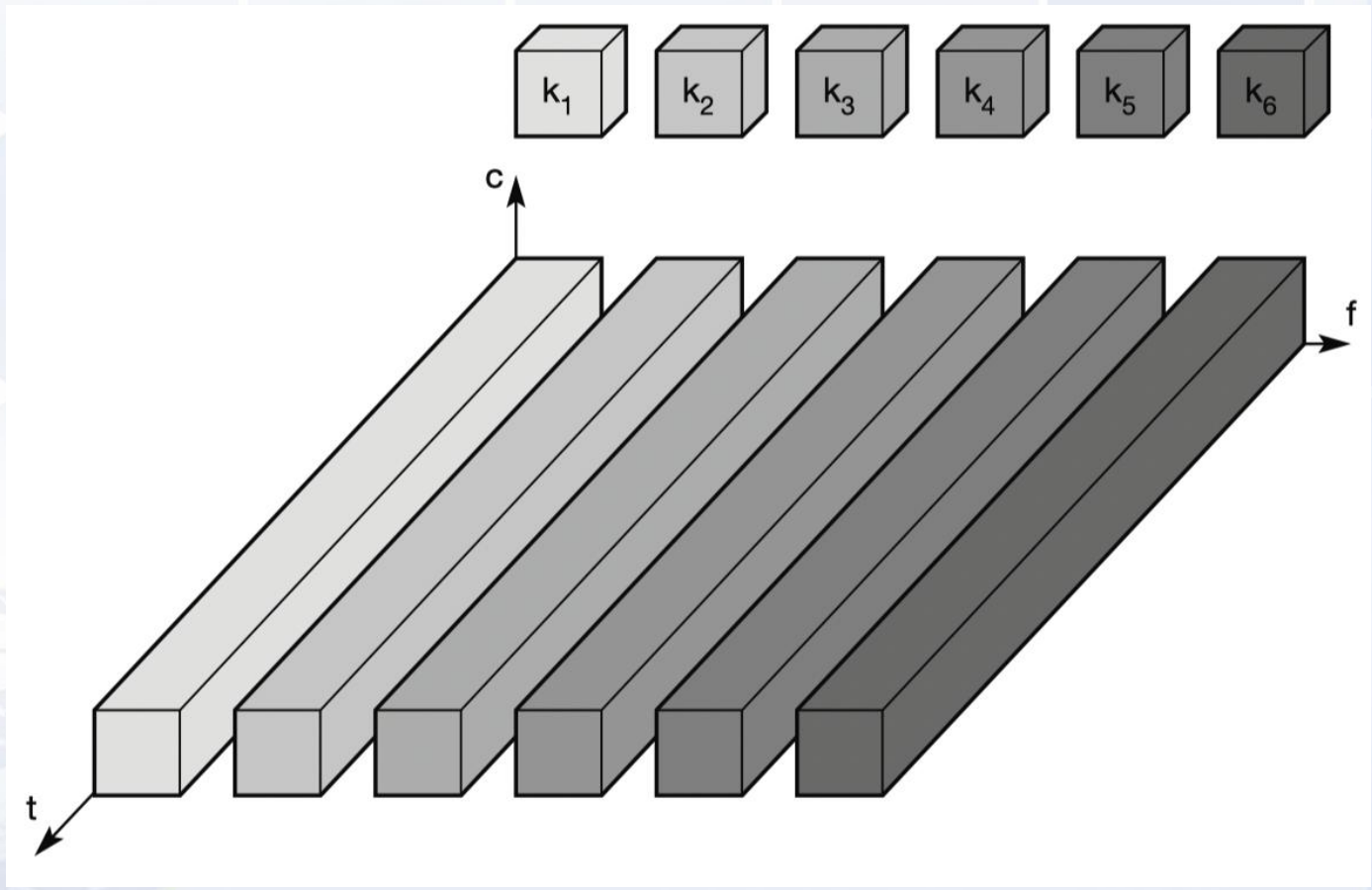

Chapter 2

Multiplexing

Time division multiplexing

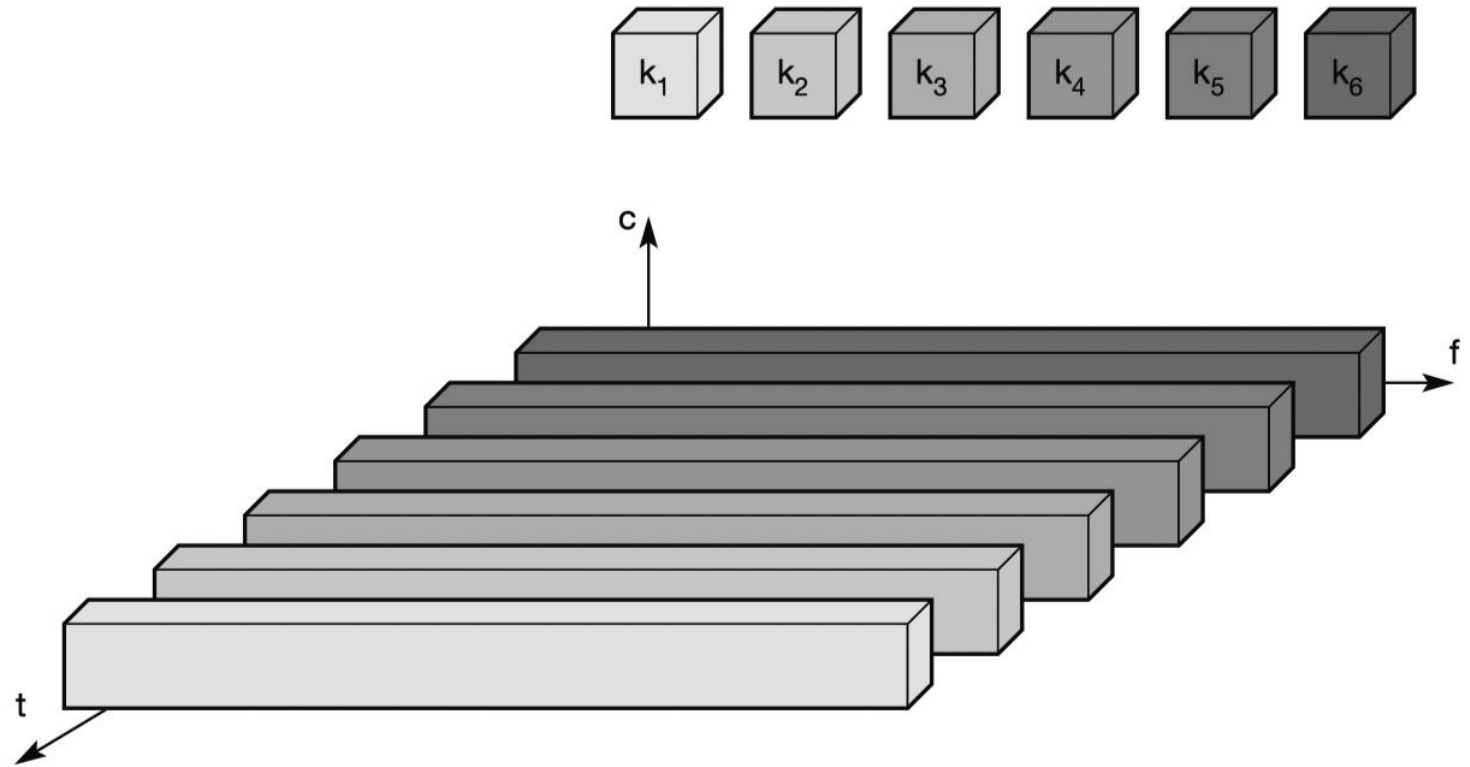

Multiplexing

Frequency and time division
multiplexing combined

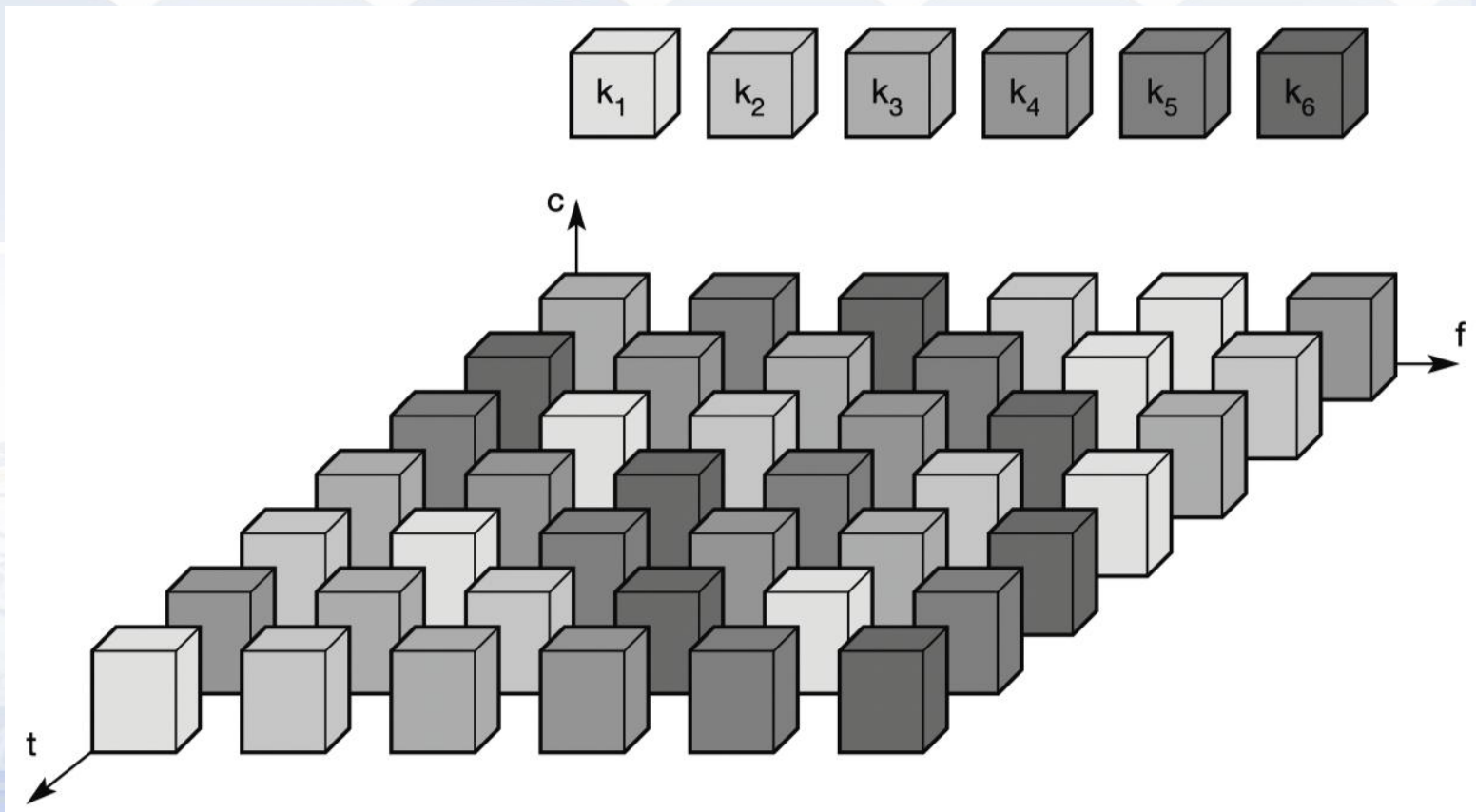

Chapter 2

Multiplexing

Code division multiplexing

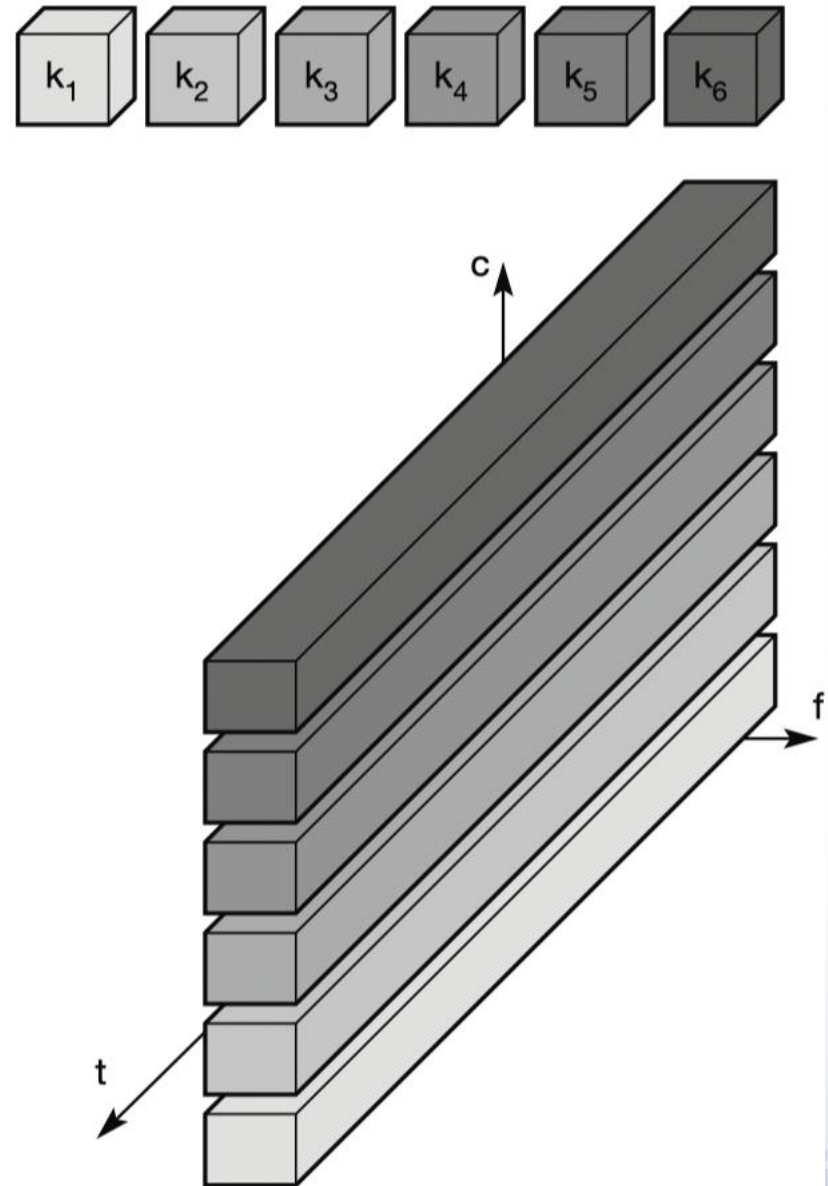

Tugas Mandiri (teori):

1. Berikan contoh penerapan dari berbagai jenis multiplexing di keseharian.
2. Bagaimana sifat gelombang saat terjadi Multipath propagation.

Tugas Mandiri (praktikum):

Instalasi Network Simulator.

end

