

Bahan Ajar

Chapter 5



Materi Pembelajaran

Matakuliah :

WIRELESS SENSOR NETWORKS

Kode Matakuliah : SKO 20428

Prodi : **SISTEM KOMPUTER**

Dosen Pengampu Matakuliah:

Bayu Nugroho, S.Kom., M.Eng

Tables of Content

Basic Wireless Sensor Technology

Sensor node Technology

Wireless Network Operating Environment

Design Constraints or Requirements for WSNs

Tugas Mandiri



Basic Wireless Sensor Technology

Sensor node Technology

1. Power.
2. Computational logic and storage.
3. Sensor transducer(s).
4. Communication.

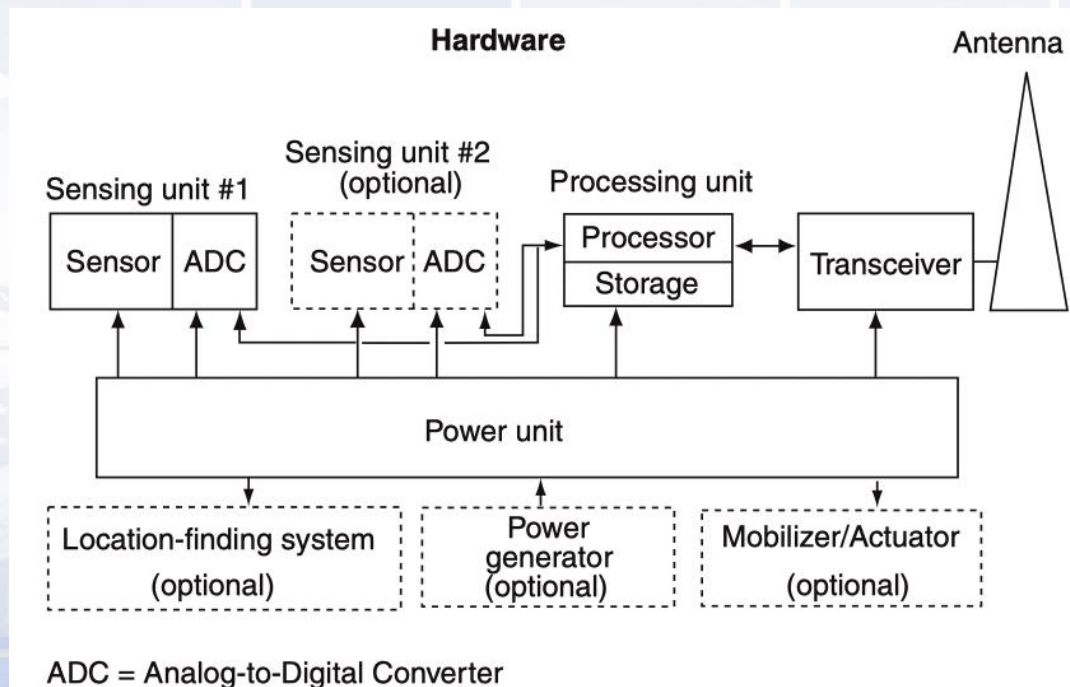

Basic Wireless Sensor Technology

Sensors typically have 5 basic software subsystems:

1. Operating system (OS) microcode (also called middleware)
2. Sensor drivers (or other peripheral)
3. Communication processors (routing, packet buffering & forwarding, topology, maintenance, medium access control)
4. Communication drivers (encoding and the physical layer)
5. Data processing mini-apps. These are numerical, data-processing, signalvalue storage and manipulations, or other basic applications that are supported at the node level for in-network processing.

Chapter 5

Basic Wireless Sensor Technology

Software components of WNs.

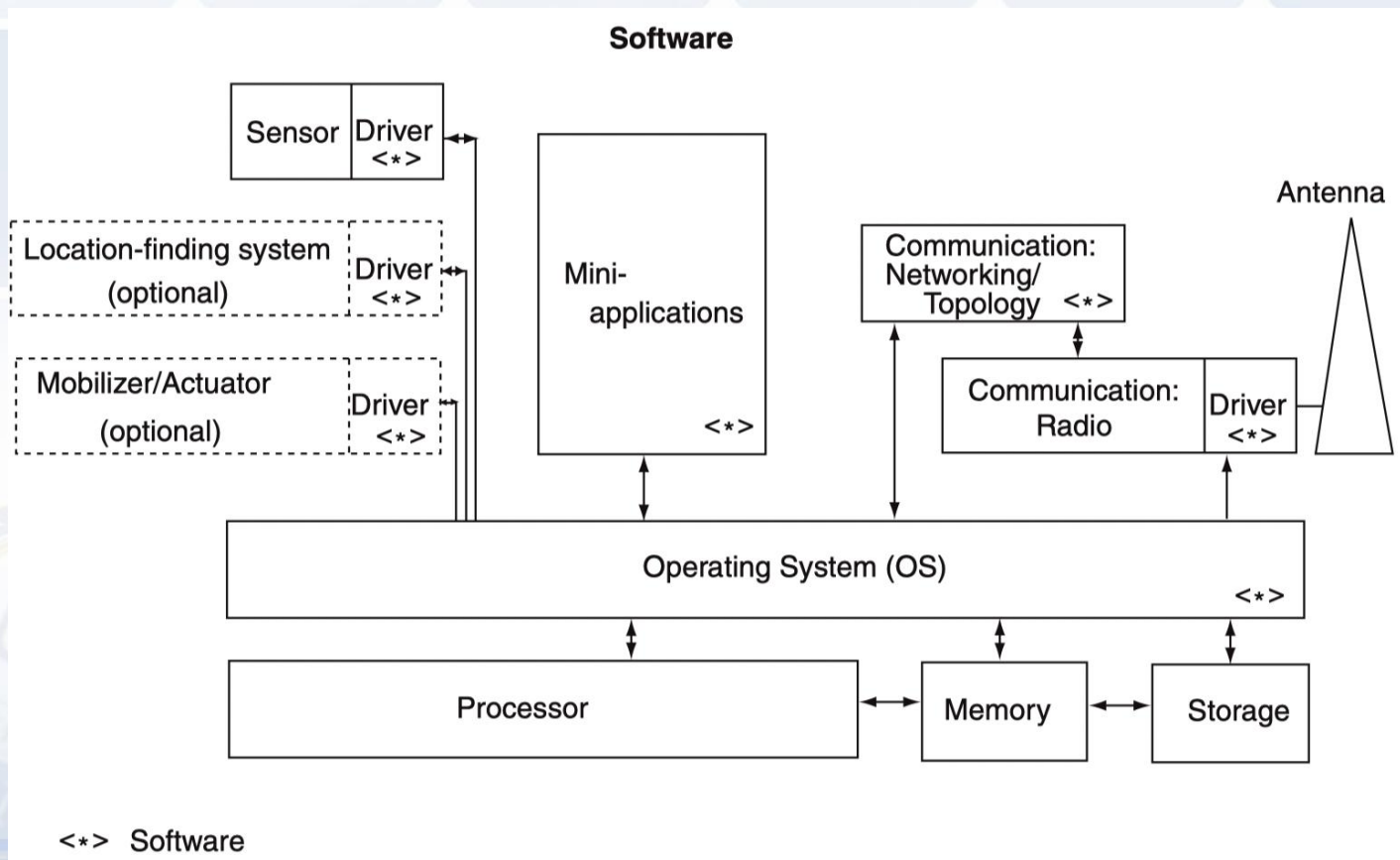

Chapter 5

Basic Wireless Sensor Technology

Complexity of Sensor Node.

Size of Sensor, s	Mobility of Sensor, m	Power of Sensor, p	Computation Logic and Storage Capability of Sensor, cp	Sensor Mode, md	Communication Apparatus or Protocols of Sensor, cm
1 Large	1 Mobile	1 Self-replenishable	1 High-end processor and storage	1 Multimodal, physics	1 Multihop/mesh with dynamic routing
2 Small	2 Static	2 Battery, hours–days	2 Midrange processor and storage	2 Multimodal, chemistry/biology	2 Single hop with static routing
3 Microscopic		3 Battery, weeks–months	3 Low-end processor and storage	3 Single function, physics	
4 Nanoscopic		4 Battery, years		4 Single function, chemistry–biology	

Wireless Network Operating Environment

In WSNs, physical connectivity is supported over a wireless radio link of one or more hops, at a distance of tens, hundreds, or thousand of meters. Logical connectivity has the goal of supporting topology maintenance and multihop routing (when present).

Sensor nodes have to deal with the following resource constraints:

- Power consumption.
- Computation.
- Communication.
- Uncertainty in measured parameters.

Design Constraints or Requirements for WSNs and WNs

- Collaborative data processing.
- Constrained energy use.
- Large topology support.
- Querying capabilities.
- Self-organization

Some of the intrinsic factors that the design constraints or requirements that WSNs and WNs need to take into account include the following:

- WNs may be deployed in a dense manner (close proximity), implying communication complexity (e.g., in support of packet forwarding and topology management).
- For military and/or national security applications, WNs need to support rapid deployment; the deployment must be supportable in an ad hoc fashion; and the environment is expected to be highly dynamic.

Chapter 5

- WNs may be prone to failure. Unattended, untethered, self-powered low-duty-cycle systems are typical, yet some WSNs require sensing systems that are long-lived and environmentally resilient.
- As just noted, WNs are limited in power, computational capacity, and memory. Communication circuitry and antennas are the primary elements that use up most of the energy.
- WNs require special routing and data dissemination mechanisms (e.g., datacentric, hierarchical, and/or location-based routing).

Chapter 5

- The topology that the WNs need to maintain may change very frequently; the bandwidth may be limited; and as just noted, the power availability at the sensor may be limited and/or expensive in reference to supporting a high-capacity, high-range link (i.e., to feed a high-power antenna).
- WNs may not have global addresses because of the potentially large number of sensors and overhead needed to support such global addresses (IPv6 could be applicable in this context).

Chapter 5

- WNs often require in-network processing, even while the data are being routed. One wants to be able to perform data processing in the network in the proximity of the source of the data, and then forward only summarized, aggregated, fused, and/or synthesized results.
- Arrays of ultralow-power wireless nodes may be incorporated in reconfigurable networks with high-speed connectivity to processing centers for decision and responsive action.

Tugas Mandiri (teori):

1. Apa kelebihan dan kekurangan dari penggunaan sensor node?
2. Kebutuhan sumber daya apa saja yang harus dipenuhi oleh sensor node? Jelaskan.

Tugas Mandiri (praktikum):

Rancang komunikasi multiple node di Network Simulator.

end

