

Bahan Ajar

Chapter 11



Materi Pembelajaran

Matakuliah :

DESAIN DAN SIMULASI RANGKAIAN ELEKTRONIKA

Kode Matakuliah : SKO 21425

Prodi : SISTEM KOMPUTER

Dosen Pengampu Matakuliah:

Bayu Nugroho, S.Kom., M.Eng

Tables of Content

Counter

Asynchronous binary counter

- Asynchronous Binary Up Counter
- Alternative Four-bit “Up” Counter
- Simultaneous “Up” and “Down” Counter

“Up” and “Down” Clock Sequence

Tugas Mandiri

Counter

Counter is a sequential logic circuit that can function to count the number of incoming pulses expressed as a binary number

In general, this counter is formed from a series of flip-flops or bistable multivibrators whose number is adjusted to the needs. According to how the pulse input into each flip-flop works, the counter can be divided into:

- **Asynchronous binary counter**
- **Synchronous binary counter**

Asynchronous binary counter

Asynchronous counters are also called serial counters, because the output of each flip flop used will roll over (changed from 0 to 1 or vice versa) sequentially.

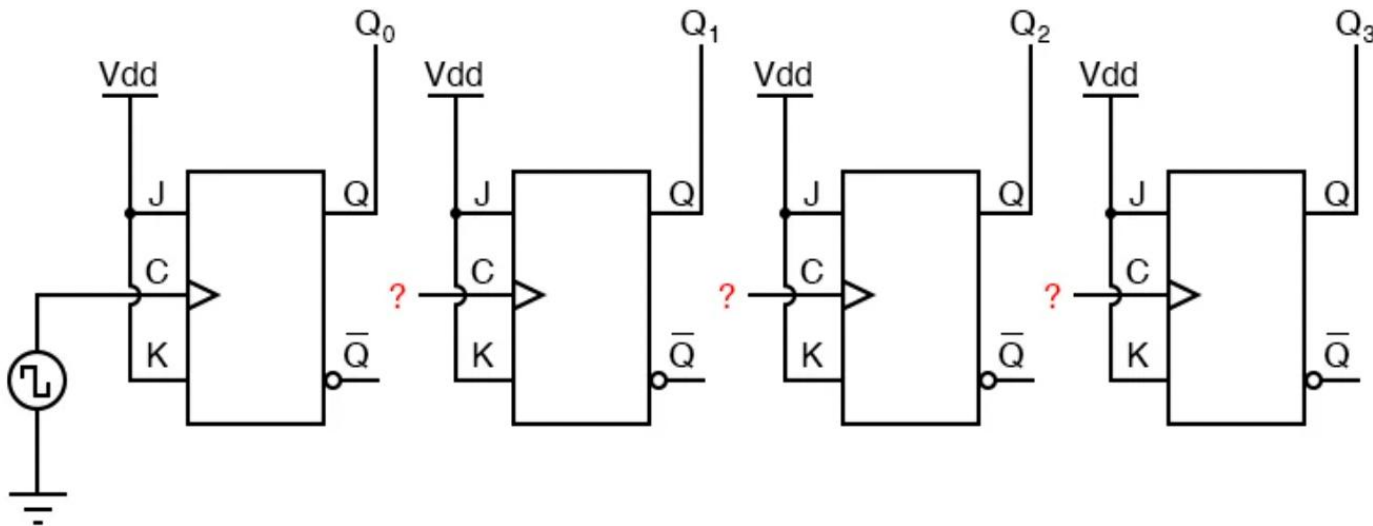

Asynchronous binary UP counter

A four-bit "up" counter

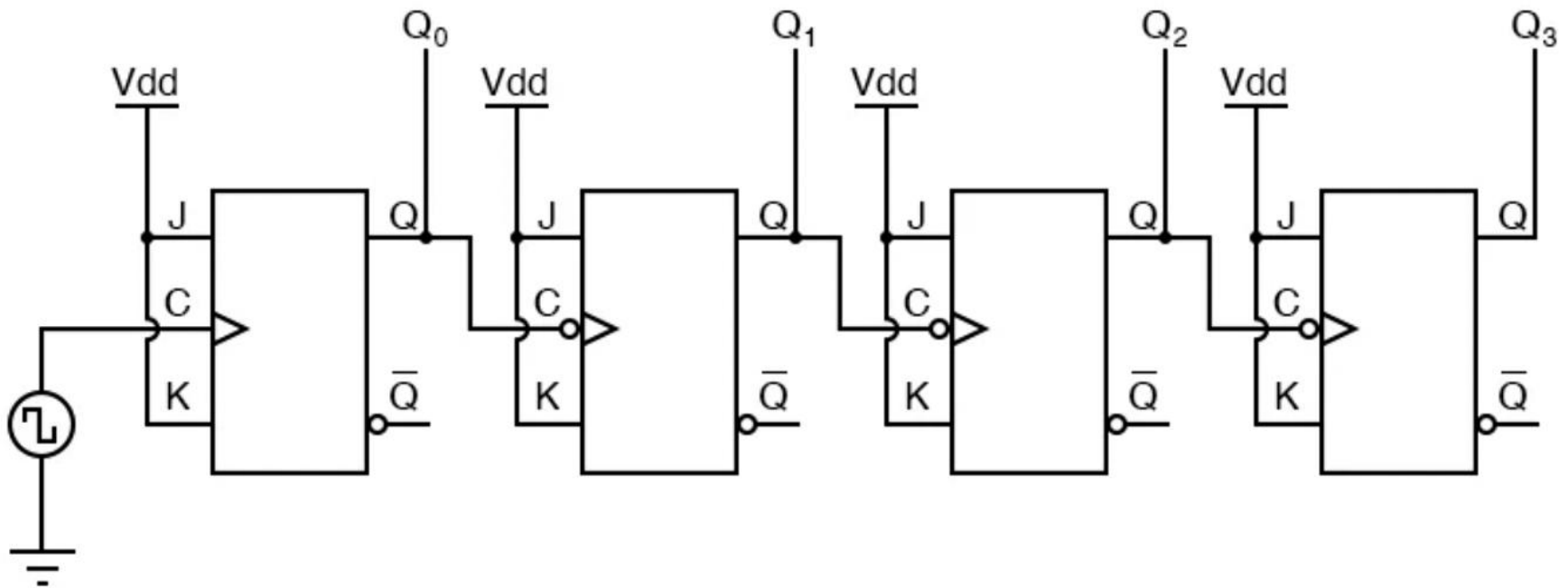

Asynchronous binary UP counter

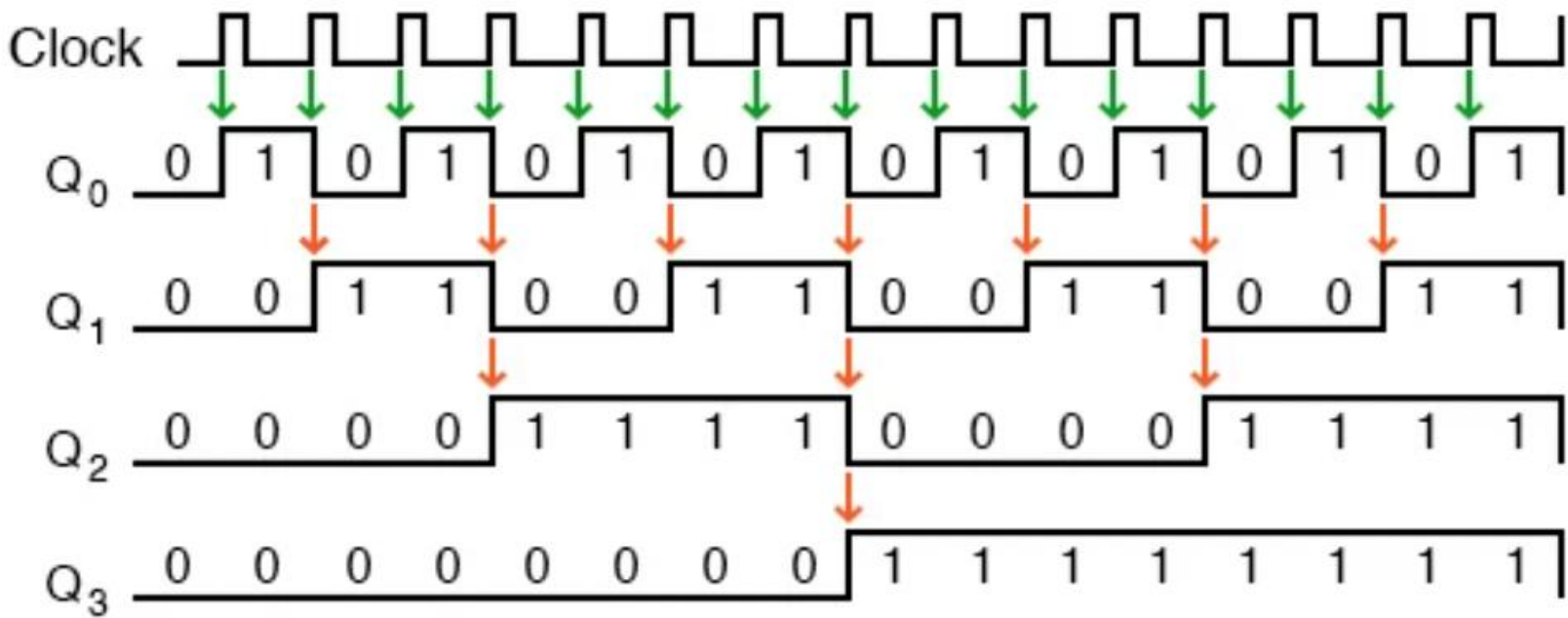

Alternative Four-bit "Up" Counter

A different way of making a four-bit "up" counter

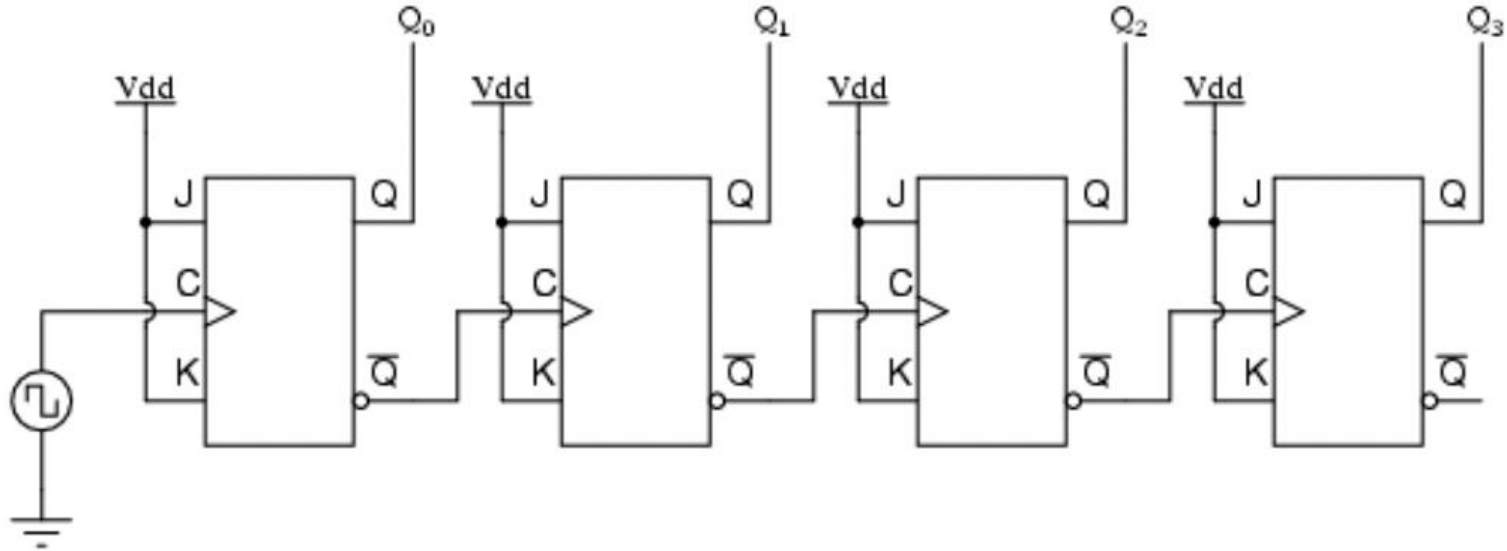

Simultaneous “Up” and “Down” Counter

A simultaneous “up” and “down” counter

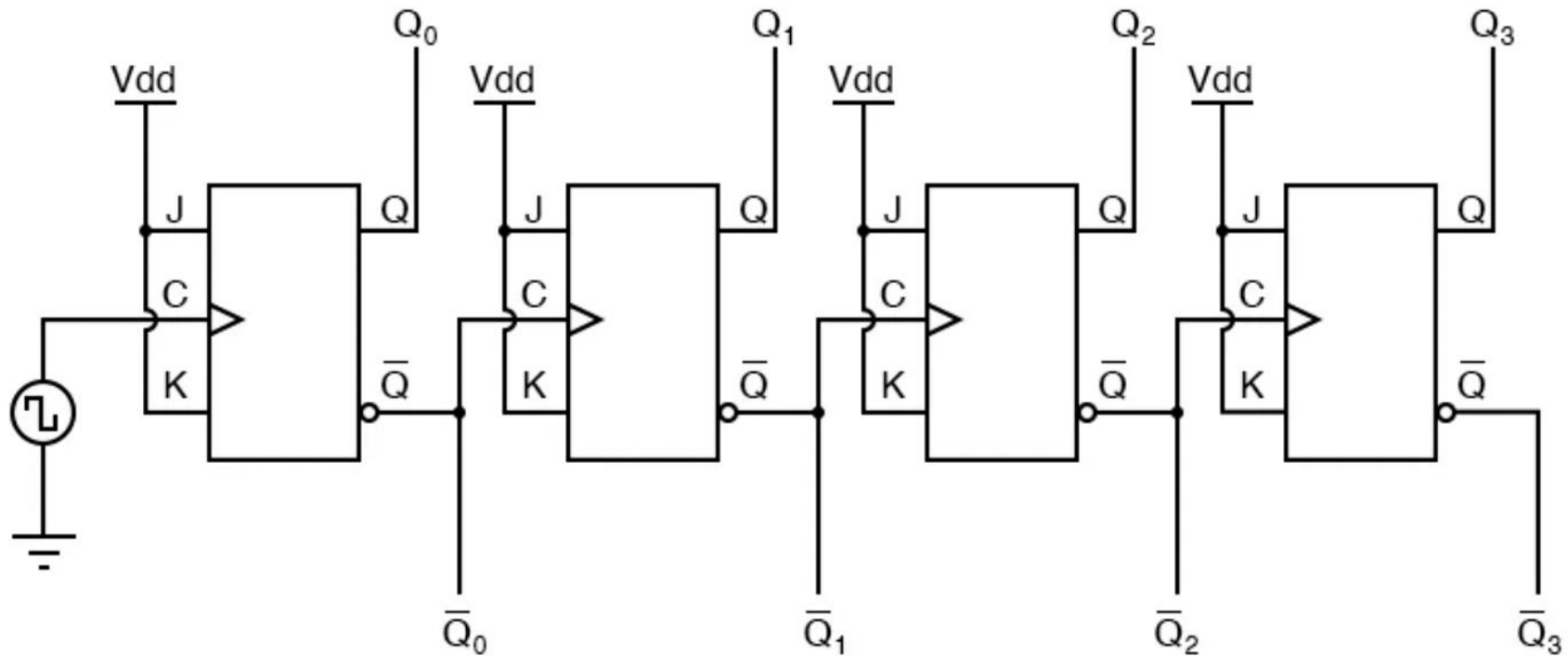

Tugas Mandiri (teori):

Lakukan pembuatan skema rangkaian Asynchronous Up dan Down Counter 7 Segment menggunakan software simulator

Tugas Mandiri (prakt):

Lakukan Simulasi Asynchronous Up dan Down Counter 7 Segment menggunakan software simulator dan jelaskan hasil simulasinya.

end

