

	A	B	C	D	E	F	G	H	I	J	K
	ID	Name	Designator	Footprint	Quantity	Manufacturer	Manufacturer	Supplier	Supplier Pa	LCSC Assembly	
1	1	HDR-M-2.54	KJ1,AJ1,BJ1	HDR-M-2.54	8			LCSC	C66690		
2	2	NE555P~NA	U1	DIP-8	1	NE555P	TI	LCSC	C46749		
3	3	MC306(6pF	C1	CAP-D3.0XF	1	HV010M05C	CapXon	LCSC	C59954		
4	4	0.1u	C63,C73	C1210K	2						
5	5	MC306(6pF	C8	C1210	1						
6	6	19-217/GHC	LED1,LED2	LED0603-R-	2	19-217/GHC	EVERLIGHT	LCSC	C72043	Yes	
7	7	1N4148W	KD1,AD1,BE	SOD-123FL	8	1N4148W	Tak Cheong	LCSC	C129216		
8	8	CAP-1uF	C2	C0805	1	RVT2A1R0N	HONOR	LCSC	C87863		
9	9	CAP-1uF	C4	RAD-0.1	1	?					
10	10	CAP-1uF	C5	R0805	1	?					
11	11	HDR-IDC-2.54	P1	IDC-TH_6P-	1	2X3 2.54mm	BOOMELE	LCSC	C11214		
12	12	0.1u	KC1,AC1,BC	C1210	8						
13	13	1KOHM	R2	R0805	1	?					
14	14	1KΩ	R1	AXIAL-0.3	1	?					
15	15	2N3906(TO	KQ1,AQ1,BE	TO-92-3_L4	8	2N3906	CJ	LCSC	C9809		
16	16	1m	KL1,AL1,BL1	L0402	8						

Export BOM supports to export LCSC part price, it is the same as LCSC website.

Notice:

- Before v6.4.17, If your project has schematic and PCB, the BOM data will come from schematic; if the project only has PCB, the BOM data will come from PCB.
- Since v6.4.17, the schematic BOM and PCB BOM are separated. If you assign the LCSC part at the PCB, it will not modify the schematic.
- In order to support multiple languages, BOM and coordinate files (CSV file) are UNICODE encoded and tab-based. If the CSV file cannot be read by your components vendor or PCB manufacturer, please convert the encoding and change the delimiter.
- Recommended solution: Save as a new CSV file in Excel or WPS. For example, open a CSV file in Excel, click or select: Save As - Other Formats - CSV (Comma Separated) (*.csv). You can also open the CSV file with any text editor (such as Windows Notepad) and save as ANSI or UTF-8 encoding. If necessary, replace all tabs with commas.

Export NetList

EasyEDA can export the netlist for the whole active project:

File > Export NetList > Spice...

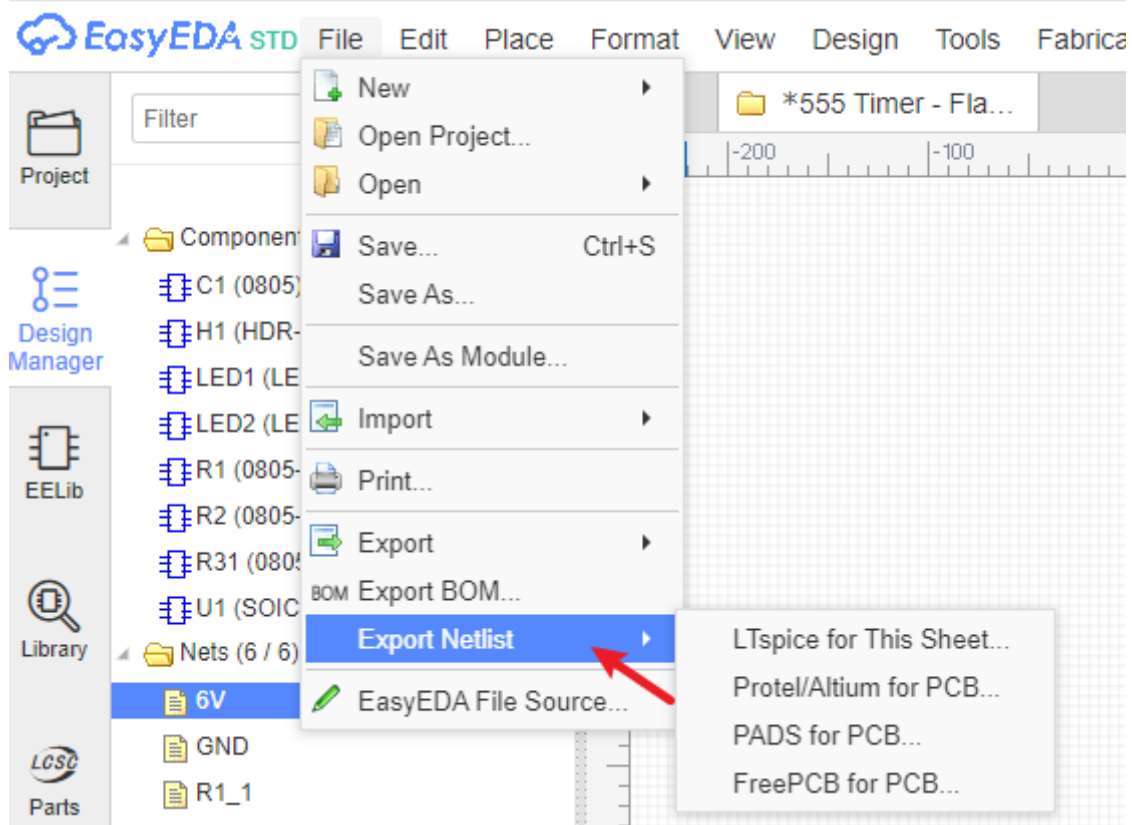

EasyEDA can export a netlist in a variety of formats:

- **LTSpice for this Sheet:** this is a Spice compatible netlist generated by the simulation engine of EasyEDA, It is not normally used as the basis for as a PCB layout.
- **Protel/Altium for PCB:** a PCB netlist in a format that can be imported straight into Altium Designer and it's predecessor, Protel.
- **PADS for PCB:** a PCB netlist in a format that can be imported straight into Pads PCB layout tools.
- **FreePCB for PCB:** a PCB netlist in a format that can be imported straight into FreePCB, a free, open source PCB editor for Windows.

Report Error

For EasyEDA official libraries, we have staffs to draw and maintain(LCSC & JLCPCB Assembled part) and we will try to keep them correctly as we can, but EasyEDA(System part) included a lot of open source of the libraries and the official drawing of the libraries, that can not avoid the wrong situation 100%, so when you meet a incorrect library, Please inform us in time, we will fix it as soon as possible.

There are 3 ways to report error:

1.Right-click the official library and use the "Report Error" function on the "Libraries".

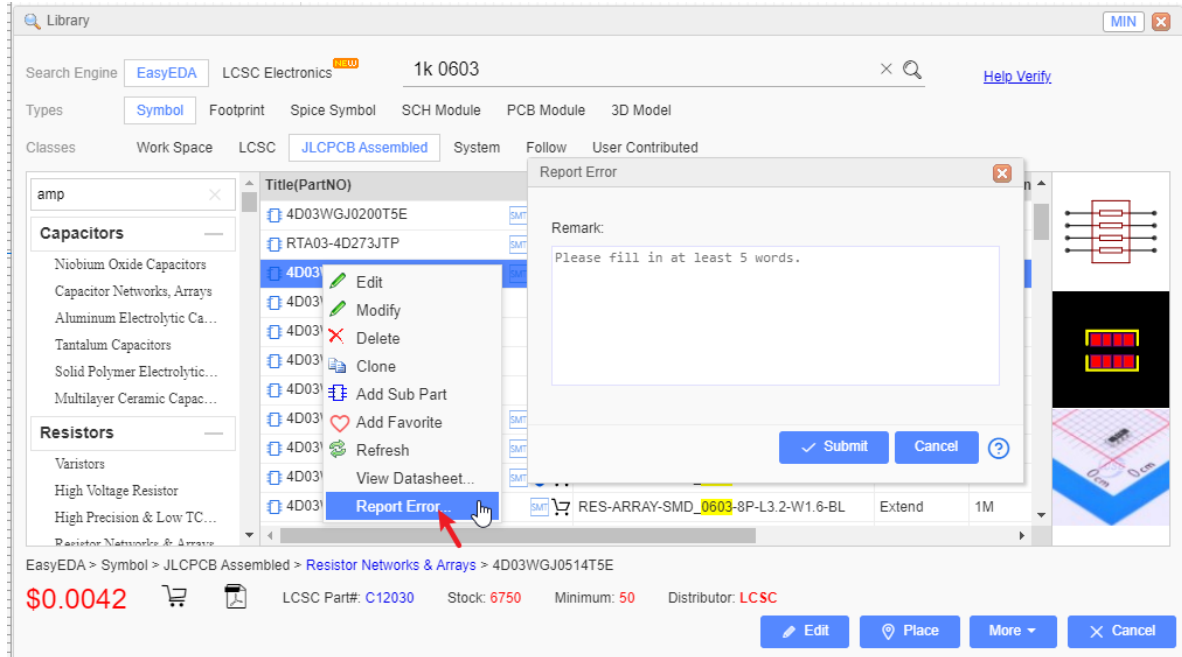

2.Select the official library on the canvas of the schematic/schematic module, click the "Report Error" button at the right-hand panel.

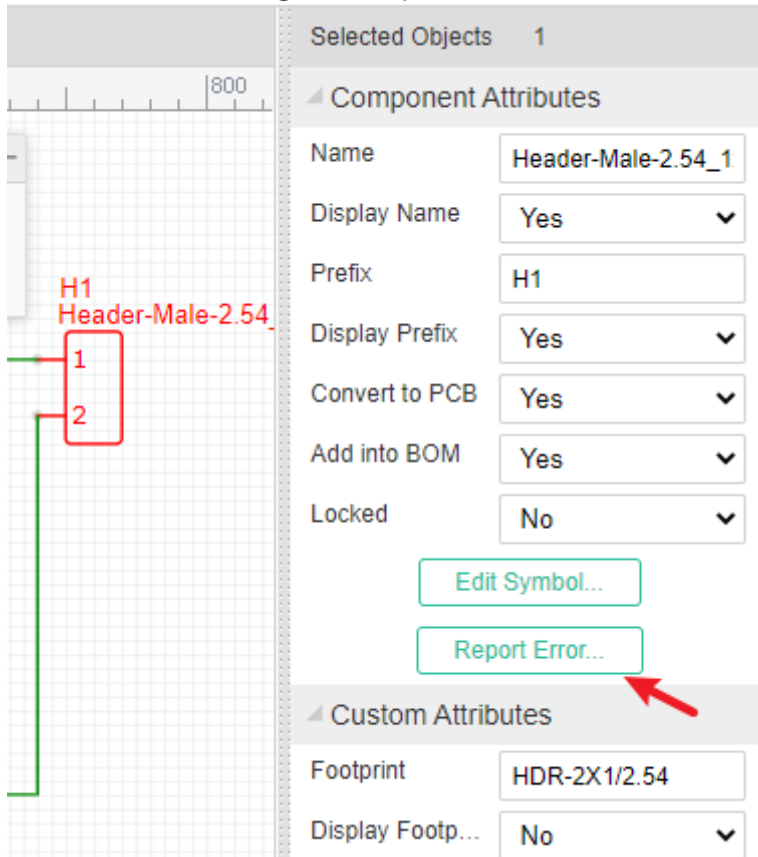

or right-click the component:

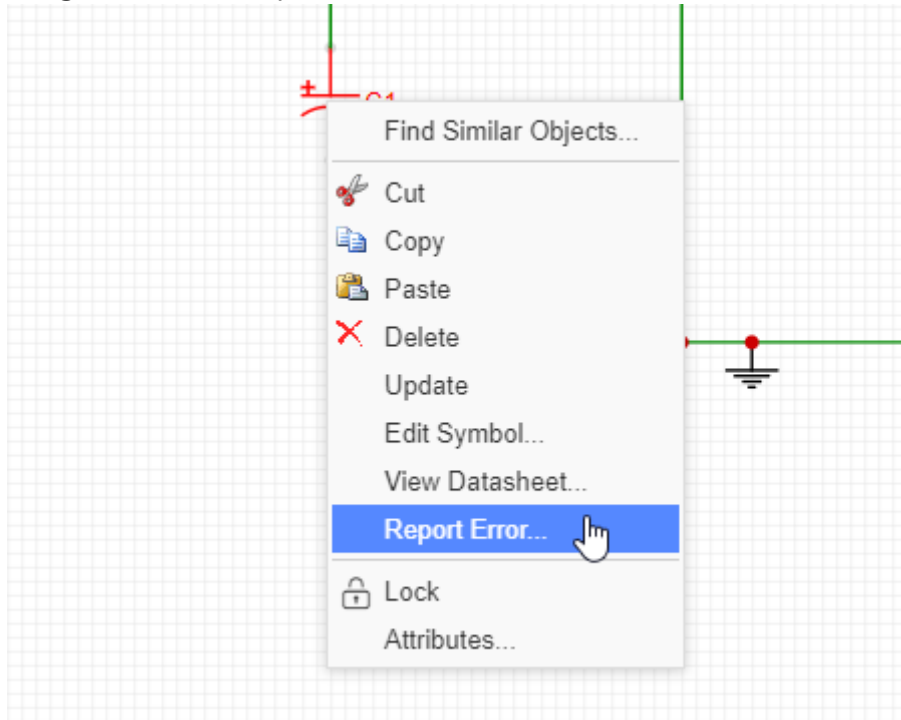

3. Send Email to us or post a topic at [Bug report](#)

support@easyeda.com

Create the Schematic Symbol

Create the Schematic Symbol

Using **Schematic Symbol Wizard** and **Group/Ungroup...** is a quick way to create schematic symbols but they are placed directly into the schematic that they are built in.

It is possible to reuse them by copying them (**CTRL+C** hotkeys) from the schematic they were created in and then cross-document-pasting them (**CTRL+SHIFT+V** hotkeys) into a different schematic but this quickly gets messy if you need to copy symbols that were created in several different schematics.

OK, you could keep copying new symbols into a dedicated “symbol library” schematic sheet to save searching for them but EasyEDA offers you an easier way to create and manage your symbols in a library.

Start a new Schematic Lib as shown below or by doing:

1. File > New > Symbol

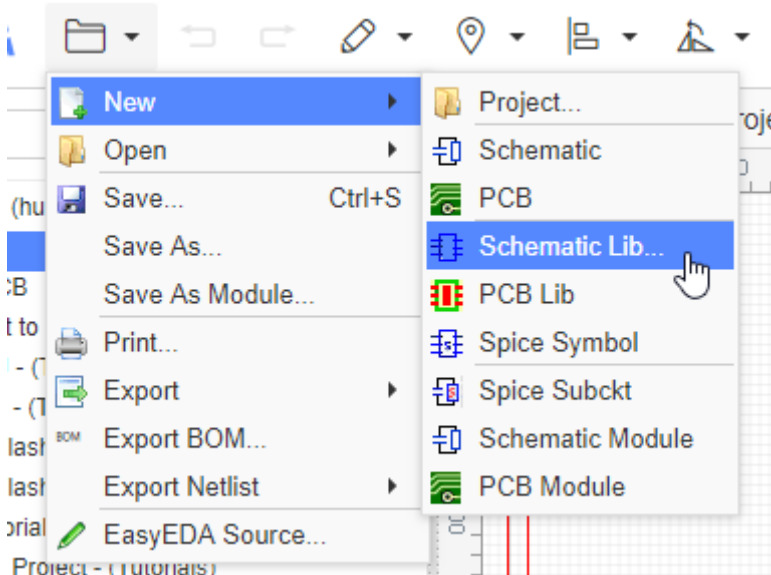

This opens the New SchematicLib symbol editor.

2. Create the symbol

- **Get the Datasheet**

For example, using the NE555DR, the datasheet you can refer [LCSC: NE555DR](https://www.lcsc.com/NE555DR).

And then create the symbol and place the pins for the library base on the datasheet.

This component have 8 pins and names.

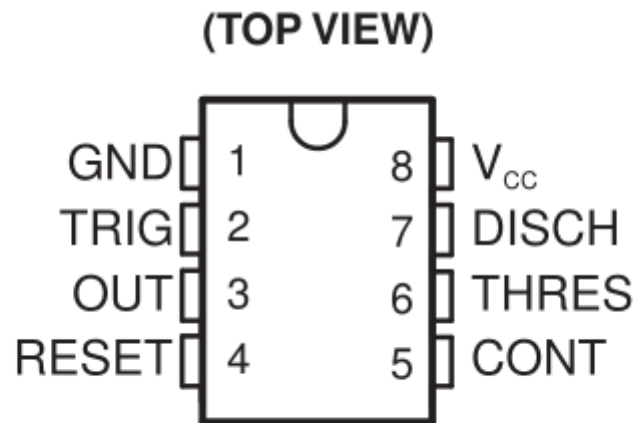

- **Create via Schematic Symbol Wizard**

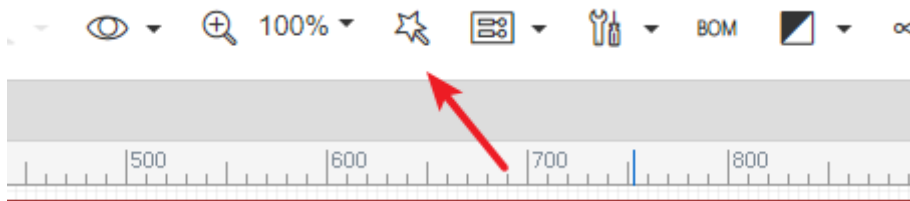

The more information of **Schematic Symbol Wizard** please refer next section.

- **Create by Manually**

- Draw the shape via the Drawing Tools

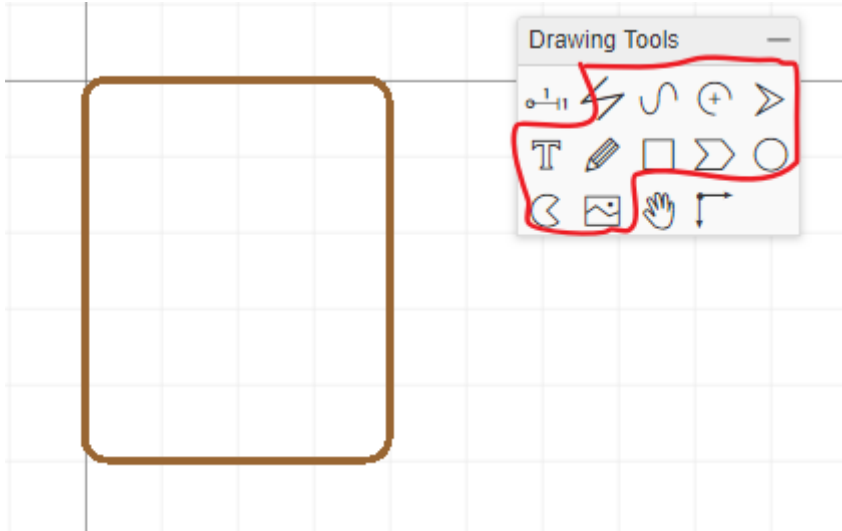

- Place the Pins

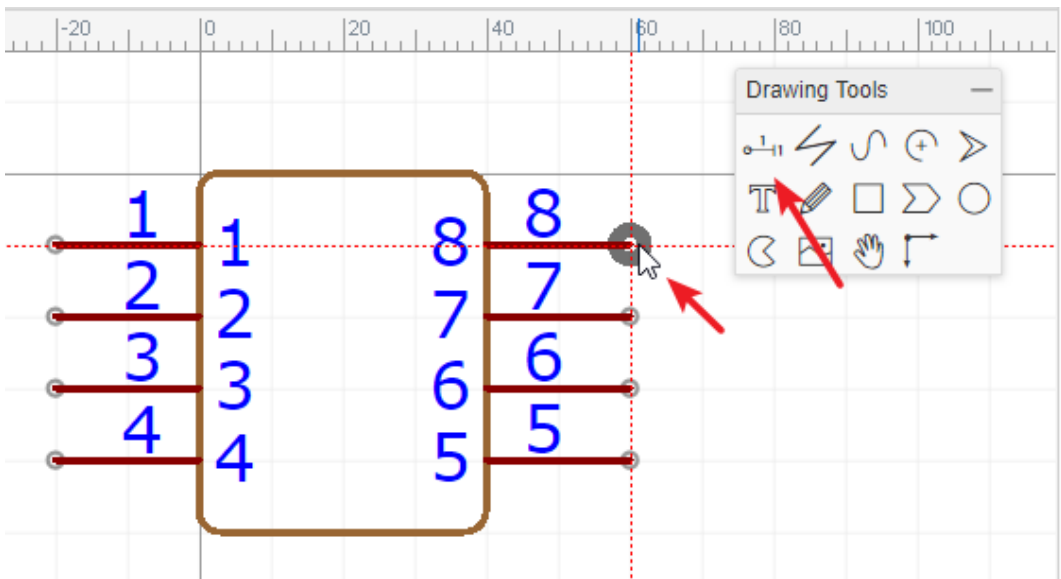

The Pin dot must keep out side as the image indicated, it is connecting with the wires. The more information please refer **SchematicLib Attributes - Pins** Section.

3. Edit the pin map

Via **Edit > Pin Map...**, change Pin names and Pin numbers. For some complicated IC, will use the alphabet for the pin number.

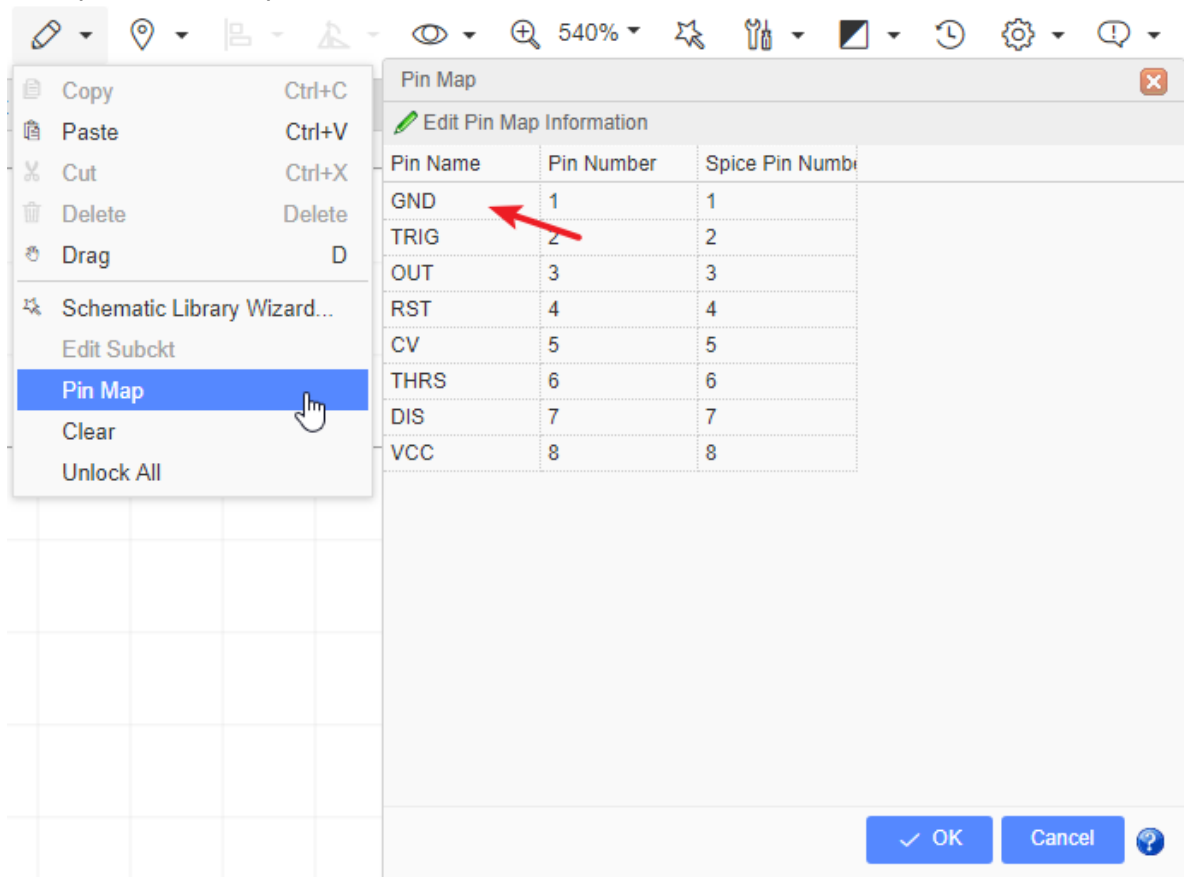

Note: if the pin is hidden, a network will be generated according to the pin name for connection. If it is not necessary, it is recommended not to hide.

4. Modify the Detail

such as change Pin length, place text, change Pin color, Pin attributes etc.

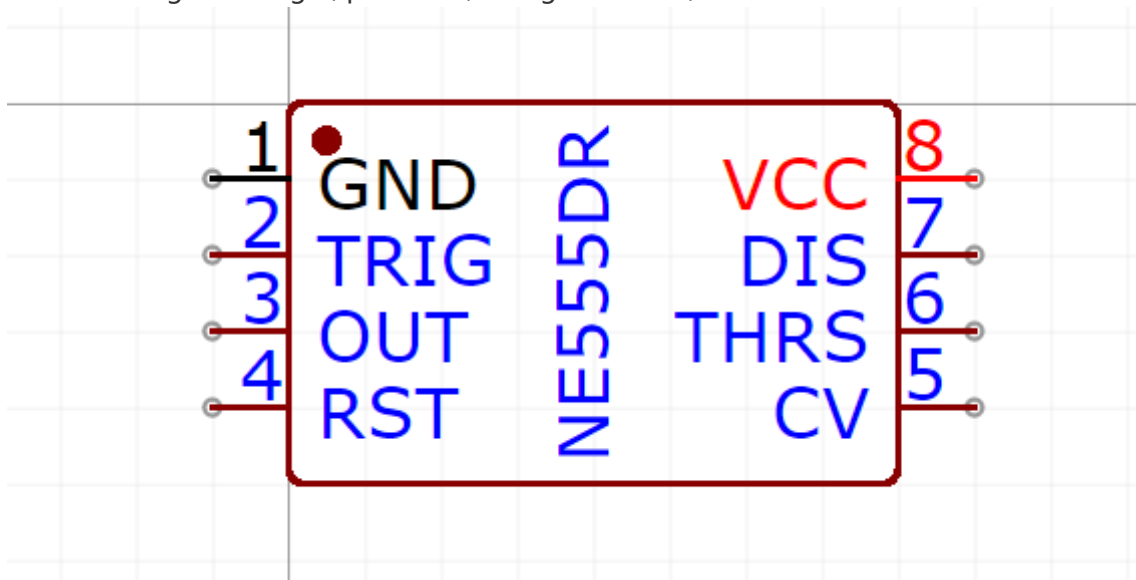

5. Set Custom Attributes

You can set the supplier, footprint (Suggested, you must assign the footprint via "Footprint Manager"), Name (Required), Prefix (Required) for it, the more detail of attributes please refer below section: **Custom Attributes**

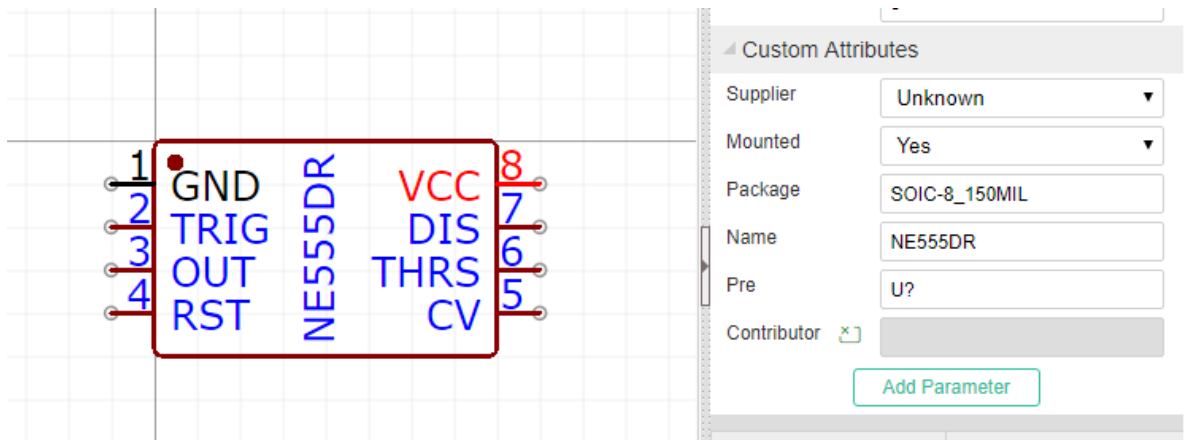

If the schematiclib need to assign the packahe, the Pin number should match the footprint's Pad number. The detail of the footprint assign please refer the **Footprint Manager** section at previous.

- If the part's property "Convert to PCB" is set as "No", it will not appear at footprint manager.

6. Set the Origin

You can via: "Top Menu - Place - Set Canvas Origin - By Center Grid of Symbols" to set the origin.

7. Save your SchameticLib

You can set this library's owner, datasheet link and tags etc.

The 'Save as a schematic Lib' dialog box contains the following fields:

Owner:	Tutorials	Create Team
Title:	NE555DR	
Manufacturer Part:	NE555DR	
Supplier:	Unknown	Or Others
Supplier Part Number:	296-6501-2-ND	
Link:	http://www.ti.com/lit/ds/symlink/ne555.pdf	
Tags:	555 Timer	
Description:	555 Timer	

Then a Schematic Symbol is created finish. And the you can find it at "Libraries - SchematicLib - Personl" on the left-hand.

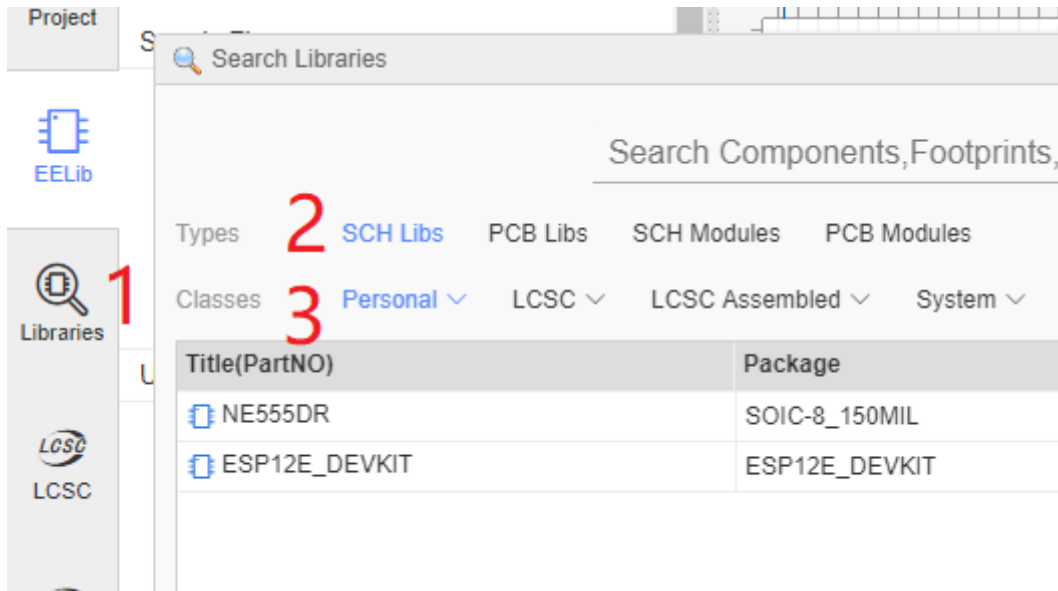

Notice:

- **Note the Origin Point.** To simplify rotating your symbols when they are placed into the canvas, make sure all of your symbols are created as near as possible centered around that point. Suggesting the first Pin/Pad or its center to be the origin point.
- *Please make sure all pins dot are placed on the grid, otherwise, when place the library on the schematic will causing the wiring difficult.*

Pin Attributes

Symbols pins are the most important part of any Schematic Lib symbol. They are the things that allow wires to be attached to symbols to connect up your circuit.

You can use the **P** hotkey to add a Pin or from the Draw Tools pallete:

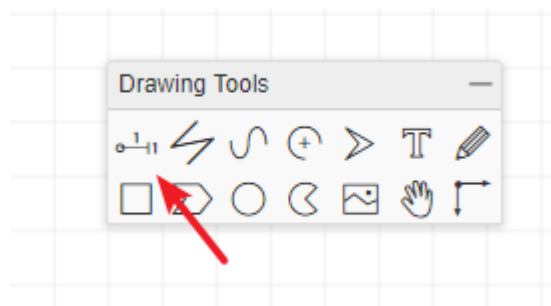

Before placing it on the canvas, you can use the rotation hotkey or rotate and flip from the menu to rotate it to the right orientation. Make sure the **Pin Dot(black dot)** is in the right position. The **Pin Dot** will be used to connect your wires or netlabels. Whenever a PIN is either placed as directly onto the canvas or as part of a symbol, the mouse has to point to the **Pin Dot** position to automatically start the Wire mode or to join a wire to it.

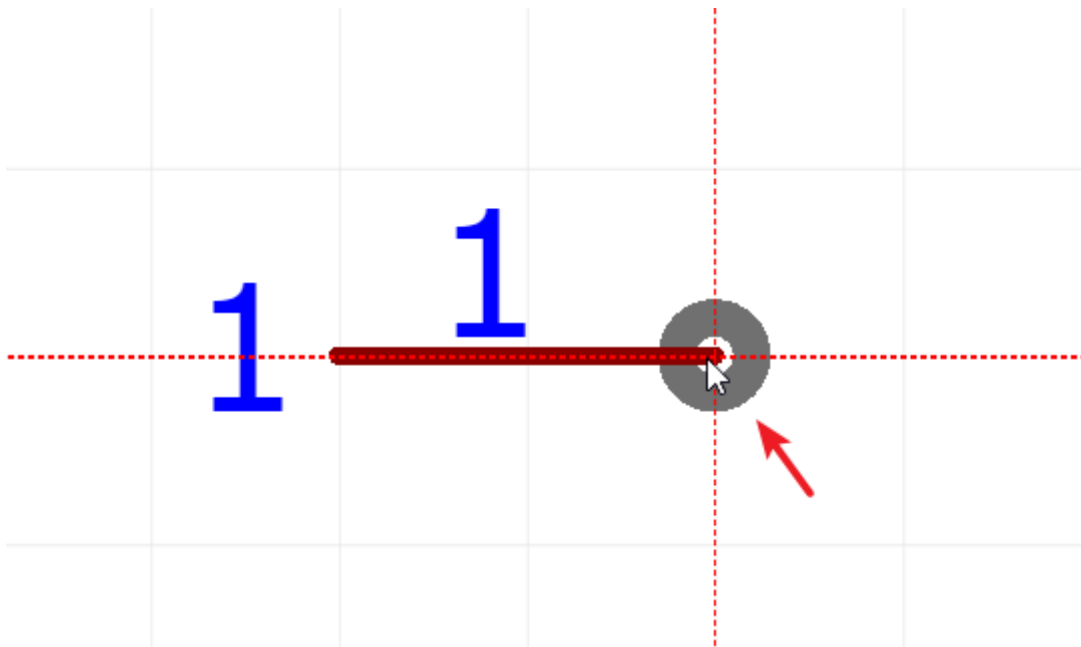

Whenever a Pin is placed as part of a symbol, the **Pin dot** should be **outside** of — and pointing away from — the symbol like in example 1(correct position), inside or pointing towards the symbol as shown in example 2(wrong position).

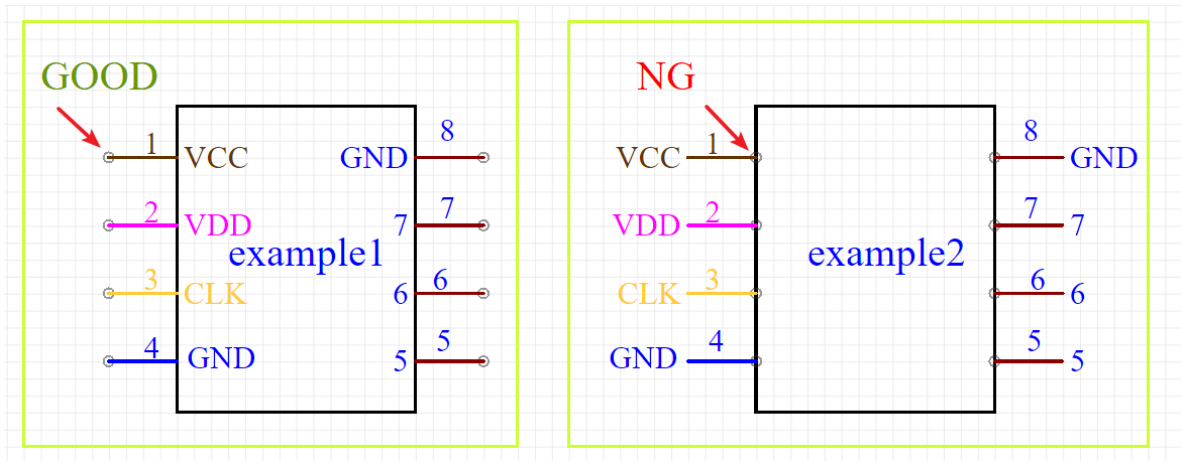

When you select a single Pin, the **Pin attributes** will be shown in the right hand **Properties** panel:

The image shows a CAD software interface with a grid and a pin symbol. The pin is labeled 'VCC' and '1'. The attribute panel on the right lists the following settings:

Attribute	Value
Selected Objects	1
Pin Attributes	
Orientation	0°
Start X	300
Start Y	90
Length	20
Name	VCC
Number	1
Spice Pin Order	1
Name Display	Yes
Number Display	Yes
Color	#880000
Dot	No
Clock	No
Show	Yes
Electric	Undefined
Font Family	Verdana
Font Size	7pt
Locked	No

Orientation: 0°,90°, 180° and 270°. If you want to create a 45° pin, you need to set it length as 0, and draw a line with 45°.

Start-X and Start-Y: The pindot position. Sometimes it may be difficult to move the pin to the desired position using the mouse, so you can move the pin via Start-X and Start-Y.

Length: Pin length.

Name: In this example, *VCC* is the name of the Pin.

Number: In this example, *1* is the number of the Pin. This number is the pin number of the device in a physical footprint.

Note that you can use alphanumeric identifiers such as; A1, B1, C1, A2, B2 and so on as the Number.

Spice Number: These are the pin numbers used to connect your symbol to the corresponding pins defined by the .model or .subckt used to simulate your device. The pin numbers of the simulation model may be different from the physical footprint pin numbers and - unless the model is specifically created to model multiple devices in a single footprint - do not change for different instances of a device in a multi-device footprint. The Spice Pin order must be **numerals** only.

Name Display: If you don't want to show *VCC*, switch it to NO.

Number Display: If you don't want to show *1*, switch it to NO.

You can adjust the Name or Number position using your mouse but note that rotate and flip applies to the whole pin including the name and pin number; these items cannot be rotated and flipped independently of the pin itself.

Note also that rotate and flip actions do not result in upside down or mirrored pin number or names.

Color: You can set the Pin to different colours, such as *PIN3:CLK* as orange and *PIN4:GND* as blue. In this example, the PIN1 is set as color #880000, but it shows as red, because it is selected. After deselecting it, the pin will appear color #880000.

Dot: adds a circle to the inside end of the pin to indicate logical (or analogue) inversion.

Clk: adds a > to the inside end of the pin to indicate that the pin is logical clock input.

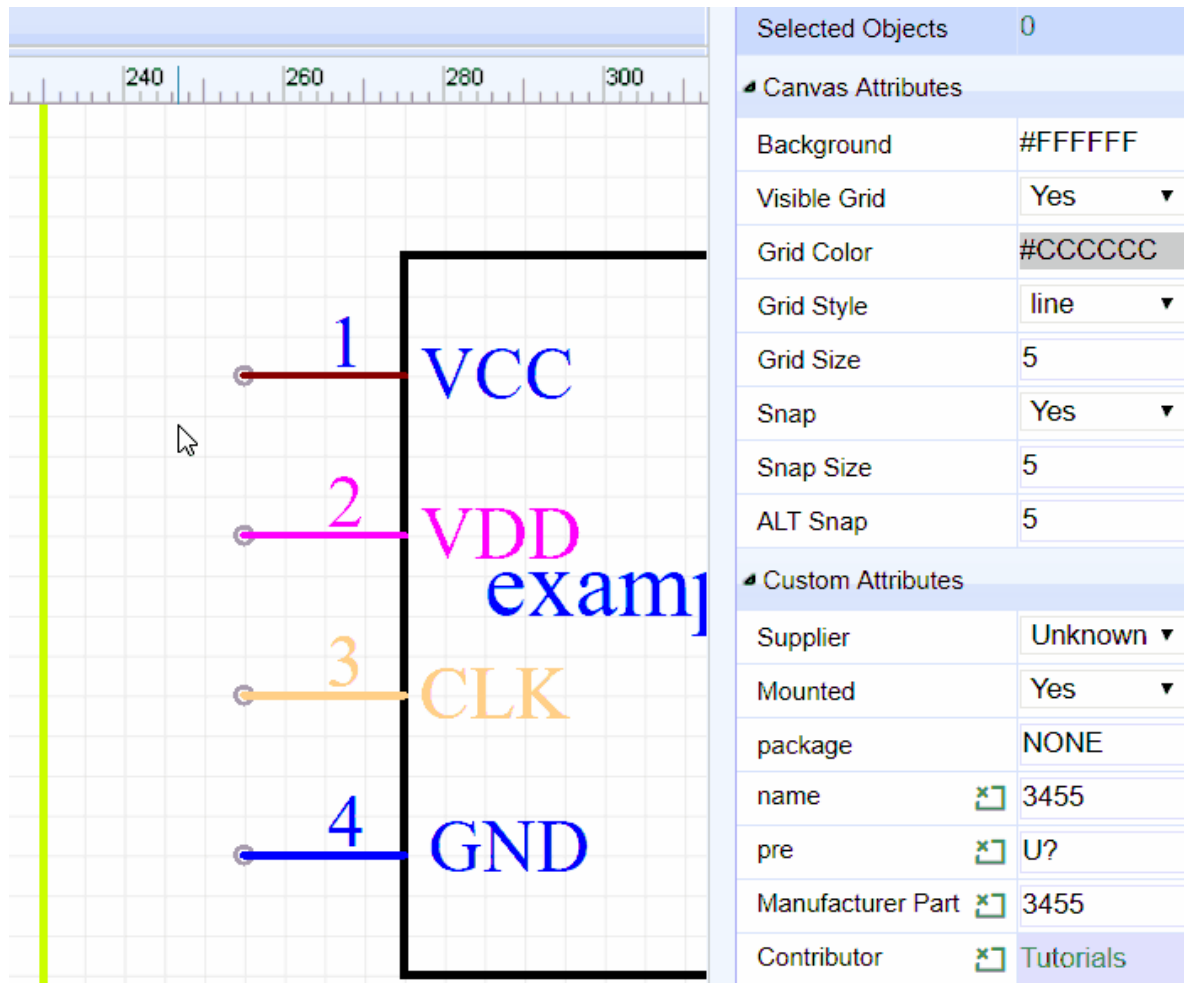

Selected Objects		0
Canvas Attributes		
Background		#FFFFFF
Visible Grid		Yes
Grid Color		#CCCCCC
Grid Style		line
Grid Size		5
Snap		Yes
Snap Size		5
ALT Snap		5
Custom Attributes		
Supplier		Unknown
Mounted		Yes
package		NONE
name		3455
pre		U?
Manufacturer Part		3455
Contributor		Tutorials

Show: YES/NO. Allows you to hide the pin. When set it to NO, this Pin will be hidden when the symbol is placed on the schematic editor canvas, and then create a net which name same as this pin name.

Note that the pin is not hidden here in the Schematic Lib symbol editor canvas because if it was, it would disappear from view and so how would you find it to make it visible again? For the same reason this option has no effect in symbols made using Group/Ungroup...

We may not have thought of everything in EasyEDA but we do try. :)

Electric: [Undefined, Input, Output, I/O, Power]

EasyEDA provides Electrical Rules Checking (ERC) right now, But you still need to set electric of your Schematic libs.

If you set the PIN as Power and set the pin to be hidden, then the Pin will be connected by Name which is the NetLabel. If the Name is VCC, it will be connected to the net in your circuit with the NetLabel or NetFlag VCC. This helps to keep the schematic clear and uncluttered when using Multi-part Components.

After created the Lib, use **CTRL+S** will open the save dialog:

Save as a schematic Lib

Owner: **Tutorials** [Create Team](#)

Title: **NE555DR**

Manufacturer Part: **NE555DR**

Supplier: **Unknown** Or

Supplier Part Number: **296-6501-2-ND**

Link: **http://www.ti.com/lit/ds/symlink/ne555.pdf**

Tags: **555 Timer**

Description: **555 Timer**

After clicking **Save**, you will see it appears in **Libraries > Symbols > Personal** of the left hand Navigation panel.

Search Libraries

Search Components, Footprints, Modules

Types: **SCH Libs** PCB Libs SCH Modules PCB Modules

Classes: **Personal** LCSC LCSC Assembled System Team Follow

Title(PartNO)	Package
NE555DR	SOIC-8_150MIL

SCH Libs > Personal > Created > 555 > NE555DR

If you want to modify the tag for your new symbol: **Libraries > Symbols > Personal > Select New Lib > More > Modify**, or **right-click new Lib > Modify**, if your Lib doesn't have the tags it will appears on **All**.

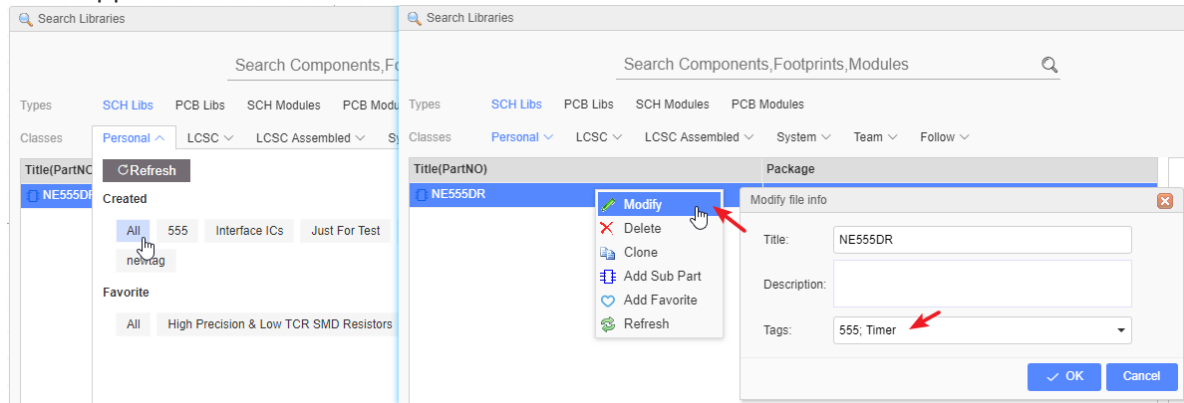

Custom Attributes

In the Schematic Lib editor's canvas Properties panel, you will find a **Custom Attributes** section:

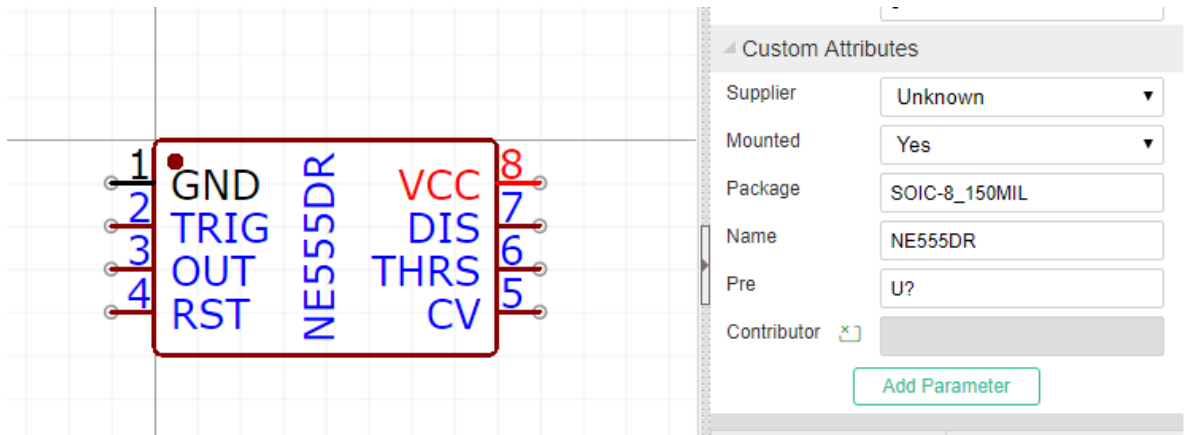

- **footprint**

How to change Schematic Symbol's footprint? If you would like to built a PCB, you need to assign a footprint for your Schematic symbol. Although there are other ways to do this in EasyEDA, here is the right place to do it. When you set a footprint , **the footprint's pad numbers must match the schematic Lib's pin number**, otherwise, when you convert the schematic to PCB , there will miss several nets.

Click in the **footprint** input box, and the **Footprint Manager** dialog will open as used to do this task in the Schematic Editor.

The more information please refer to **Schematic - Footprint Manager** section.

Notie:

You have to assign the footprint via the Footprint Manager, otherwise, the Schematic lib will not get the footprint correctly. The footprint is linked with SchematicLib by global unique ID not the title.

- **Prefix**

The default Schematic symbol Prefix is **U?** If you create a resistor, you can set the Prefix to **R?**. It is filled required.

- **Name**

You can change the schematic lib's name here, it is can be different from the part's file name.

- **Contributor**

This is your registered user name. When Other EasyEDA's users use your libraries, they will remember your contributions!

Symbol Subparts

We have already touched on how EasyEDA can support **Multi-part/Subpart Components** , but how do you create **multi-part components**?

EasyEDA provides a sub parts facility to do this.

After creating a part, you can right-click the part in the **Library > Symbols > Work Space > Created** section to pop up the content menu.

Suppose you have created your own symbol for a 74HCT04 hex inverter.

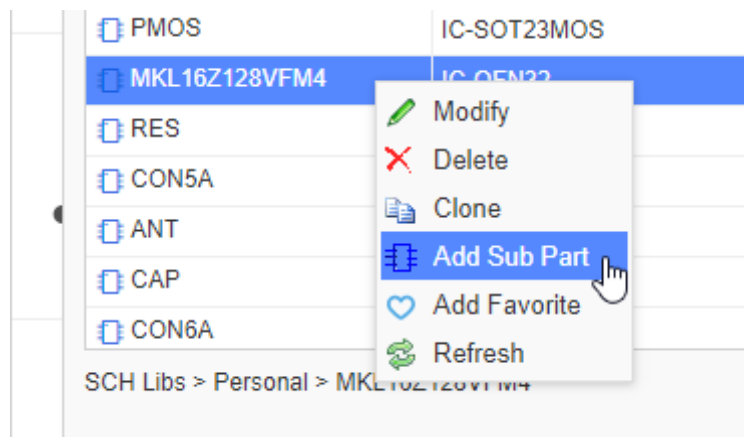

Right Click **Add sub part** and that will add 74HCT04.1,

Click again to add 74HCT04.2, up to 74HCT04.6.

Then double click on each sub part in turn to modify the Pin Name and Number attributes.

Easy or what?

Schematic Symbol Wizard

How many times have you hit a schematic capture roadblock because you couldn't find a component symbol?

Well, in EasyEDA that would be never because the **Schematic Symbol Wizard** provides a quick and easy way to create a general Schematic Symbol symbol.

Via: Top Menu - Tools - Symbol Wizard

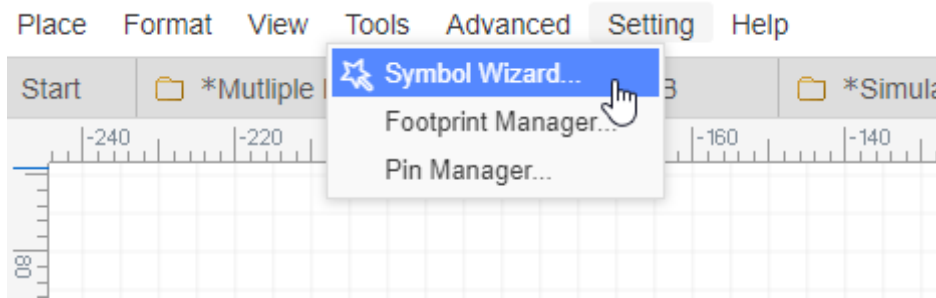

Basic Function

Input the Pins' name Only

- Using the **NE555** timer as an example: this device is available in a **DIP8** package so select **DIP**. Then enter the NE555 pin names into the **Pin Names** text box separated by new line or space, Then press OK. Abracadabra! As if by magic, you will find a perfectly formed dual in line 8 pin symbol for the NE555 attached to your mouse cursor, ready to be placed! You just need a few seconds to build a NE555 symbol, quickly and easily.

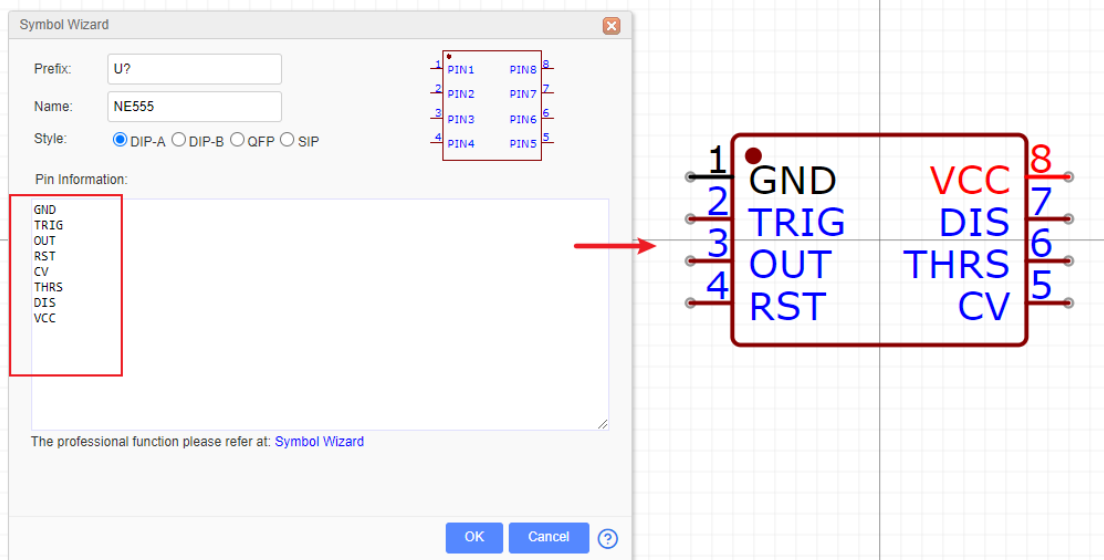

- The EasyEDA Schematic Symbol Wizard allows you to create DIP, QFP or SIP styles symbols. If you are designing Arduino Shields then you will need lots of SIP symbol, so you can create a SIP symbol like the one shown below in a few seconds.

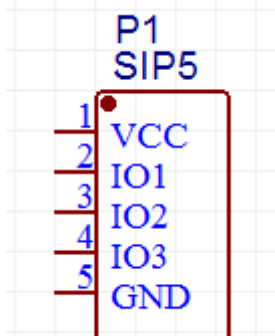

- If you are not too worried that the symbols may not look quite the way people might expect and that they may not look anything like the Type you select, then of course you

can use the wizard to create symbols for any component:

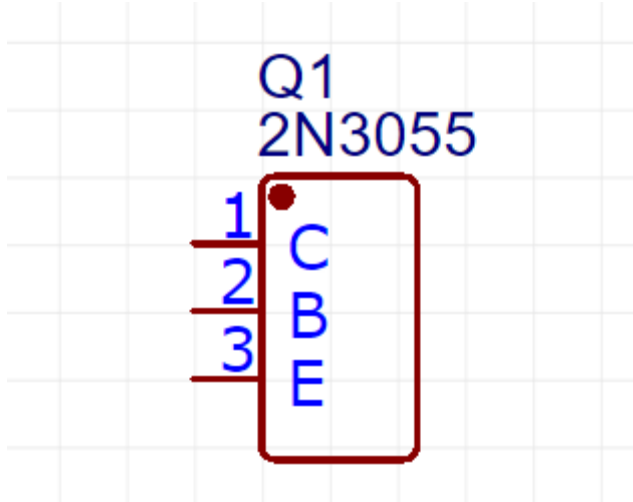

Input the Pins' number and name

Schematic Symbol wizard support you input the pins' number and name. As below example, setting every pin's number is easily.

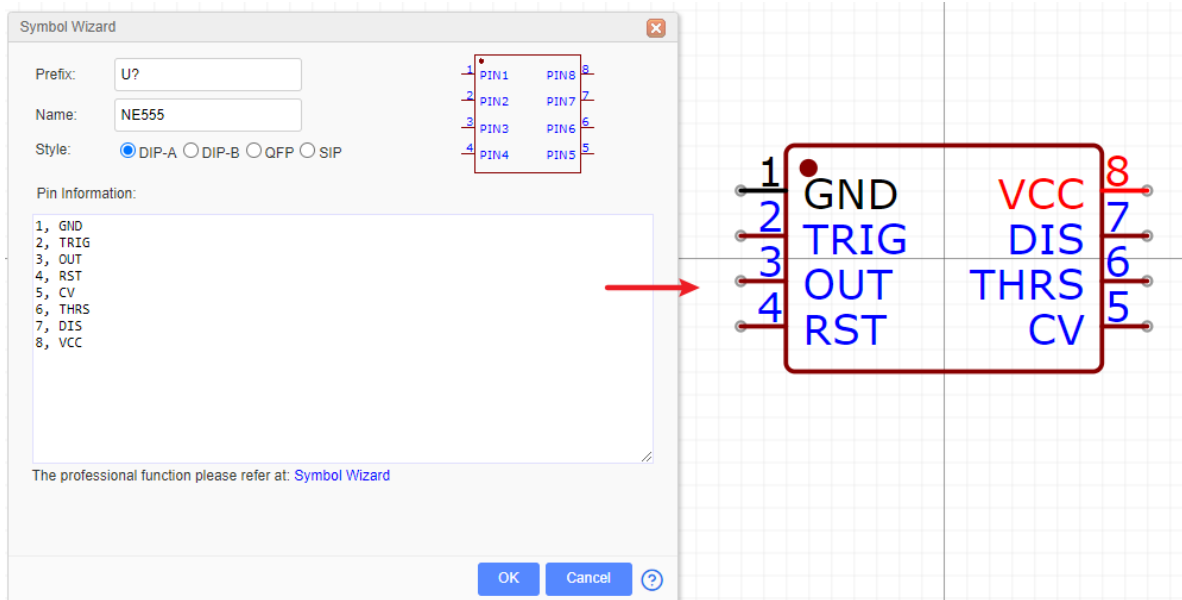

Professional Function

Schematic Symbol Wizard support the professional function, it is easier to create the large and complex and more convenient Schematic Symbol.

1. Download [Schematic Symbol Wizard Template.xlsx](#)

2. Open it via Excel or WPS, and edit each Pins attributes and position, and then copy the content and paste in wizard dialog without content title.

Tip: If you want to create the gap between Pin and Pin, you can use the * as below image.

Number	Name	Number Display	Name Display	Clock	Show	Electric	Position
1	GND	Yes	Yes	No	Yes	Undefined	Bottom
2	TRIG	Yes	Yes	No	Yes	Undefined	Left
*	*	*	*	*	*	*	Left
3	OUT	Yes	Yes	No	Yes	Undefined	Left
4	RST	Yes	Yes	No	Yes	Undefined	Top
*	*	*	*	*	*	*	Top
5	CV	Yes	Yes	No	Yes	Undefined	Right
*	*	*	*	*	*	*	Right
6	THRS	Yes	Yes	No	Yes	Undefined	Right
*	*	*	*	*	*	*	Right
7	DIS	Yes	Yes	No	Yes	Undefined	Right
8	VCC	Yes	Yes	No	Yes	Undefined	Top

3.The Wizard will create the symbol follow your content. The types you chosen will be ignored.

Symbol Wizard

Prefix: U?

Name: NE555

Style: DIP-A DIP-B QFP SIP

Pin Information:

1	GND	Yes	Yes	No	Yes	Undefined	Bottom
2	TRIG	Yes	Yes	No	Yes	Undefined	Left
*	*	*	*	*	*	*	Left
3	OUT	Yes	Yes	No	Yes	Undefined	Left
4	RST	Yes	Yes	No	Yes	Undefined	Top
*	*	*	*	*	*	*	Top
5	CV	Yes	Yes	No	Yes	Undefined	Right
*	*	*	*	*	*	*	Right
6	THRS	Yes	Yes	No	Yes	Undefined	Right
*	*	*	*	*	*	*	Right
7	DIS	Yes	Yes	No	Yes	Undefined	Right
8	VCC	Yes	Yes	No	Yes	Undefined	Top

The professional function please refer at: [Symbol Wizard](#)

OK Cancel ?

Notice:

- If the content you input wasn't one, two or eight columns, it will shown incorrect format.
- You can use the Key Space to separate the column data.

Schematic Symbol Attributes

Pin Attributes

Symbols pins are the most important part of any Schematic Lib symbol. They are the things that allow wires to be attached to symbols to connect up your circuit.

You can use the **P** hotkey to add a Pin or from the Draw Tools palette:

Number	Name	Number Display	Name Display	Clock	Show	Electric	Position
1	GND	Yes	Yes	No	Yes	Undefined	Bottom
2	TRIG	Yes	Yes	No	Yes	Undefined	Left
*	*	*	*	*	*	*	Left
3	OUT	Yes	Yes	No	Yes	Undefined	Left
4	RST	Yes	Yes	No	Yes	Undefined	Top
*	*	*	*	*	*	*	Top
5	CV	Yes	Yes	No	Yes	Undefined	Right
*	*	*	*	*	*	*	Right
6	THRS	Yes	Yes	No	Yes	Undefined	Right
*	*	*	*	*	*	*	Right
7	DIS	Yes	Yes	No	Yes	Undefined	Right
8	VCC	Yes	Yes	No	Yes	Undefined	Top

3.The Wizard will create the symbol follow your content. The types you chosen will be ignored.

Symbol Wizard

Prefix: U?

Name: NE555

Style: DIP-A DIP-B QFP SIP

Pin Information:

1	GND	Yes	Yes	No	Yes	Undefined	Bottom
2	TRIG	Yes	Yes	No	Yes	Undefined	Left
*	*	*	*	*	*	*	Left
3	OUT	Yes	Yes	No	Yes	Undefined	Left
4	RST	Yes	Yes	No	Yes	Undefined	Top
*	*	*	*	*	*	*	Top
5	CV	Yes	Yes	No	Yes	Undefined	Right
*	*	*	*	*	*	*	Right
6	THRS	Yes	Yes	No	Yes	Undefined	Right
*	*	*	*	*	*	*	Right
7	DIS	Yes	Yes	No	Yes	Undefined	Right
8	VCC	Yes	Yes	No	Yes	Undefined	Top

The professional function please refer at: [Symbol Wizard](#)

OK Cancel ?

Notice:

- If the content you input wasn't one, two or eight columns, it will shown incorrect format.
- You can use the Key Space to separate the column data.

Schematic Symbol Attributes

Pin Attributes

Symbols pins are the most important part of any Schematic Lib symbol. They are the things that allow wires to be attached to symbols to connect up your circuit.

You can use the **P** hotkey to add a Pin or from the Draw Tools palette:

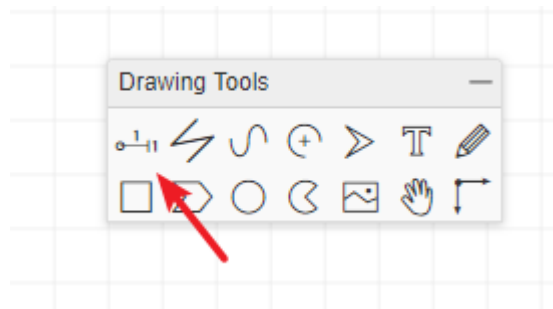

Pin Orientation

Before placing it on the canvas, you can use the rotation hotkey or rotate and flip from the menu to rotate it to the right orientation. Make sure the **Pin Dot (black dot)** is in the right position. The **Pin Dot** will be used to connect your wires or netlabels. Whenever a PIN is either placed as directly onto the canvas or as part of a symbol, the mouse has to point to the **Pin Dot** position to automatically start the Wire mode or to join a wire to it.

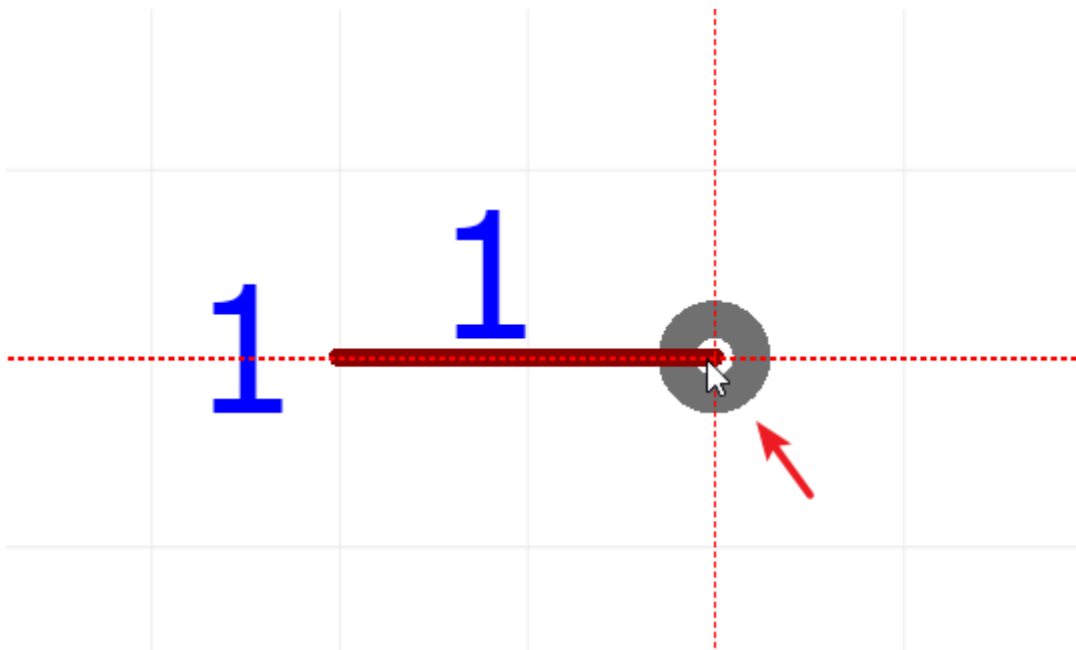

Whenever a Pin is placed as part of a symbol, the **Pin dot** should be **outside** of — and pointing away from — the symbol like in example 1 (correct position), inside or pointing towards the symbol as shown in example 2 (wrong position).

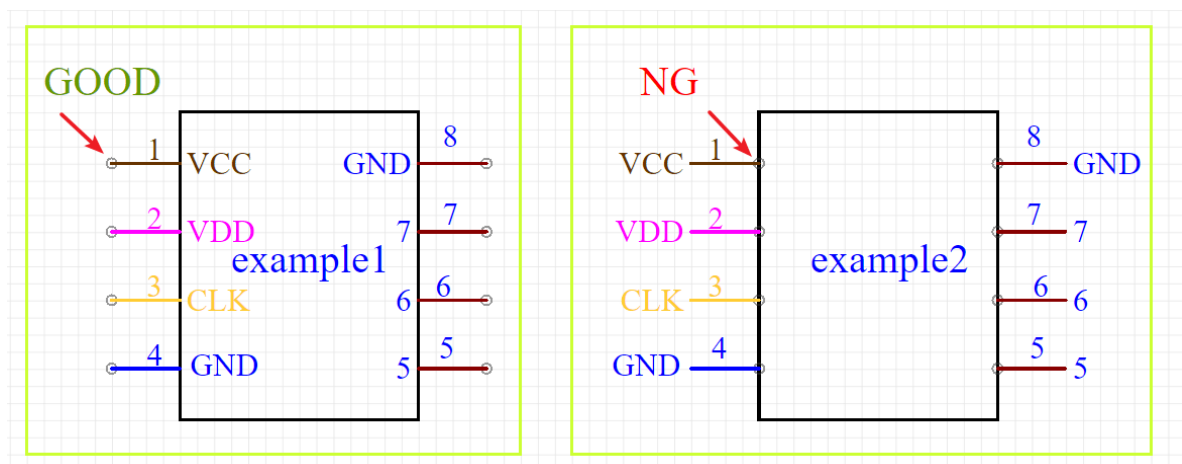

Pin Attributes

When you select a single Pin, the **Pin attributes** will be shown in the right hand **Properties** panel:

The image shows a CAD software interface with a grid and a pin symbol. The pin is labeled 'VCC' and '1'. The attribute panel on the right lists the following settings:

Attribute	Value
Selected Objects	1
Pin Attributes	
Orientation	0°
Start X	300
Start Y	90
Length	20
Name	VCC
Number	1
Spice Pin Order	1
Name Display	Yes
Number Display	Yes
Color	#880000
Dot	No
Clock	No
Show	Yes
Electric	Undefined
Font Family	Verdana
Font Size	7pt
Locked	No

Orientation: 0°,90°, 180° and 270°. If you want to create a 45° pin, you need to set it length as 0, and draw a line with 45°.

Start-X and Start-Y: The pindot position. Sometimes it may be difficult to move the pin to the desired position using the mouse, so you can move the pin via Start-X and Start-Y.

Length: Pin length.

Name: In this example, *VCC* is the name of the Pin.

Number: In this example, *1* is the number of the Pin. This number is the pin number of the device in a physical footprint

Note that you can use alphanumeric identifiers such as; A1, B1, C1, A2, B2 and so on as the Number.

Spice Number: These are the pin numbers used to connect your symbol to the corresponding pins defined by the .model or .subckt used to simulate your device. The pin numbers of the simulation model may be different from the physical footprint pin numbers and - unless the model is specifically created to model multiple devices in a single footprint - do not change for different instances of a device in a multi-device footprint. The Spice Pin order must be **numerals** only.

Display Name: If you don't want to show *VCC*, switch it to NO.

Display Number: If you don't want to show *1*, switch it to NO.

You can adjust the Name or Number position using your mouse but note that rotate and flip applies to the whole pin including the name and pin number; these items cannot be rotated and flipped independently of the pin itself.

Note also that rotate and flip actions do not result in upside down or mirrored pin number or names.

Color: You can set the Pin to different colours, such as *PIN3:CLK* as orange and *PIN4:GND* as blue. In this example, the PIN1 is set as color #880000, but it shows as red, because it is selected. After deselecting it, the pin will appear color #880000.

Dot: adds a circle to the inside end of the pin to indicate logical (or analogue) inversion.

Clock: adds a > to the inside end of the pin to indicate that the pin is logical clock input.

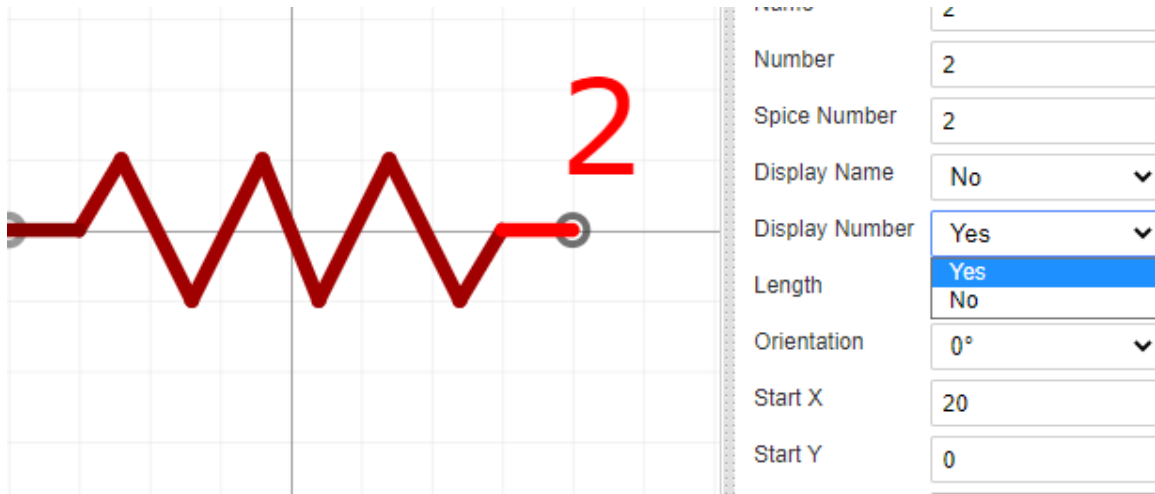

Show: YES/NO. Allows you to hide the pin. When set it to NO, this Pin will be hidden when the symbol is placed on the schematic editor canvas.

Note that the pin is not hidden here in the Schematic Lib symbol editor canvas because if it was, it would disappear from view and so how would you find it to make it visible again? For the same reason this option has no effect in symbols made using Group/Ungroup...

We may not have thought of everything in EasyEDA but we do try. :)

Electric: [Undefined, Input, Output, I/O, Power]

EasyEDA provides Electrical Rules Checking (ERC) right now, But you still need to set electric of your Schematic libs.

If you set the PIN as Power and set the pin to be hidden, then the Pin will be connected by Name which is the NetLabel. If the Name is VCC, it will be connected to the net in your circuit with the NetLabel or NetFlag VCC. This is helps to keep the schematic clear and uncluttered when using Multi-part Components.

After created the Lib, use **CTRL+S** will open the save dialog:

Save as a schematic Lib

Owner: **Tutorials** [Create Team](#)

Title: **NE555DR**

Manufacturer Part: **NE555DR**

Supplier: **Unknown** Or **Others**

Supplier Part Number: **296-6501-2-ND**

Link: **http://www.ti.com/lit/ds/symlink/ne555.pdf**

Tags: **555 Timer**

Description: **555 Timer**

Save

After clicking **Save**, you will see it appears in **Libraries > Symbols > Personal** of the left hand Navigation panel.

Search Libraries

Search Components, Footprints, Modules

Types: **SCH Libs** | PCB Libs | SCH Modules | PCB Modules

Classes: **Personal** | LCSC | LCSC Assembled | System | Team | Follow

Title(PartNO)	Package
NE555DR	SOIC-8_150MIL

SCH Libs > Personal > Created > 555 > NE555DR

If you want to modify the tag for your new symbol: **Libraries > Symbols > Personal > Select New Lib > More > Modify**, or **right-click new Lib > Modify**, if your Lib doesn't have the tags it will appear on **All**.

Search Libraries

Search Components, Footprints, Modules

Types: **SCH Libs** | PCB Libs | SCH Modules | PCB Modules

Classes: **Personal** | LCSC | LCSC Assembled | System | Team | Follow

Created: **All** | 555 | Interface ICs | Just For Test

Favorite: **All** | High Precision & Low TCR SMD Resistors

NE555DR

- Modify
- Delete
- Clone
- Add Sub Part
- Add Favorite
- Refresh

Modify file info

Title: **NE555DR**

Description:

Tags: **555; Timer**

Symbol Custom Attributes

In the Schematic Lib editor's canvas Properties panel, you will find a **Custom Attributes** section:

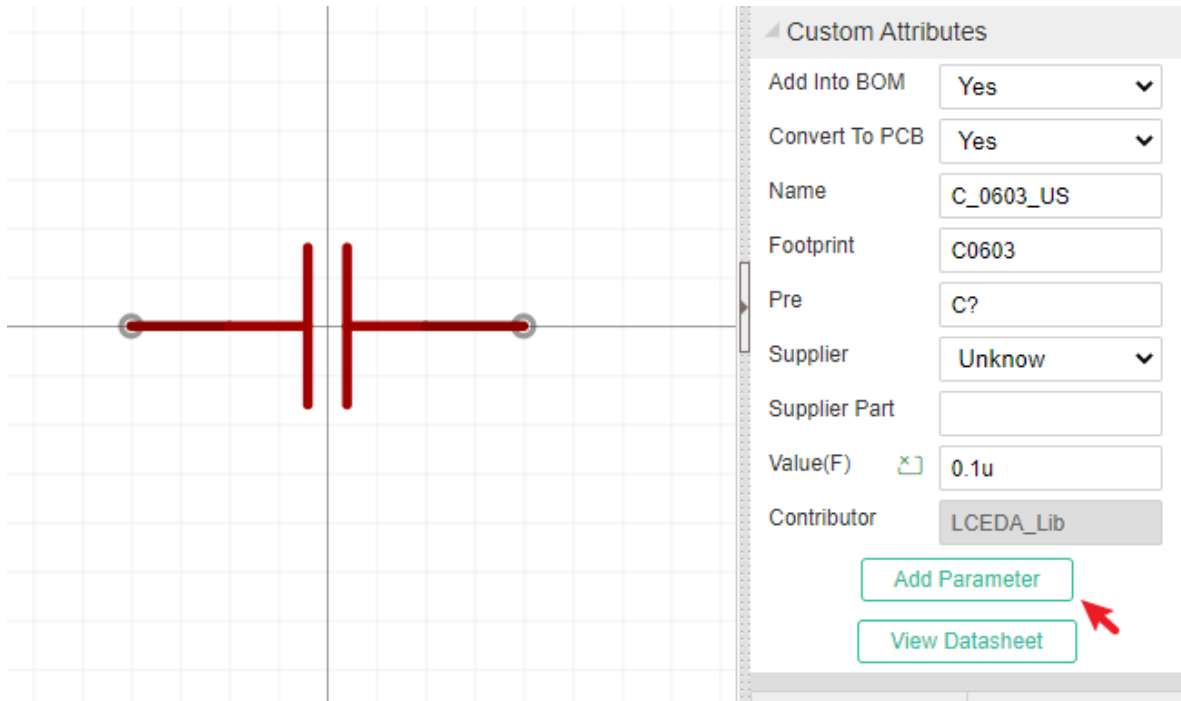

- **Add into BOM**
This part display at BOM or not.
- **Convert to PCB**
If you set it as No, this part will not display at Footprint Manager and can't not convert to PCB.
- **footprint**
To assign a footprint for this part. Only assign one footprint.
The more information please refer to **Schematic - Footprint Manager** section.
Notie:
You have to assign the footprint via the Footprint Manager, otherwise, the Schematic Symbol will not corresponding the Footprint correctly. The Footprint is linked with Symbol by global unique ID not the title.
- **Pre**
The default Schematic symbol Prefix is **U?** If you create a resistor, you can set the Prefix to **R?**. It is filled required.
- **Name**
You can change the schematic lib's name here, it is can be different from the part's file name.
- **Contributor**
This is your registered user name. When Other EasyEDA's users use your libraries, they will remember your contributions!

Show symbol value as component name when place component at schematic

For example, a resistor symbol vaule is 2K Ω , name is ABC, but when place it at schematic, it will not show 2K Ω as component name, the name is ABC. You can change name to 2K Ω , but it not very well.

EasyEDA doesn't support common function to support this feature yet.

But, we can edit the symbol file source to implement this feature.

How do it works:

1. Finish symbol and parameter edit.
2. Open file source. via: Top Menu - File - EasyEDA File Source.

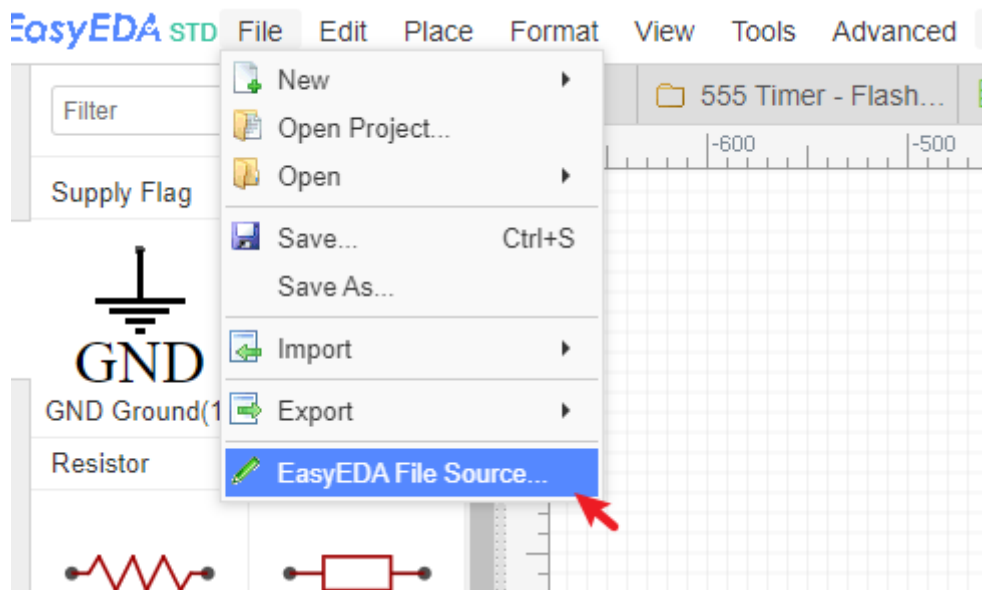

3. Add or modify the parameter: nameAlias.



This symbol will show 1k as component name after placing at schematic.

4. Apply after modified, and save.

You can double click the EELib resistor symbol to get an example.

EasyEDA will provide it as a feature in the future.

Edit Exited Schematic Symbol

Personal Libraries

When you **CTRL+S** to save the Schematic Symbol, will pop up a dialog, you can choose this library's owner:

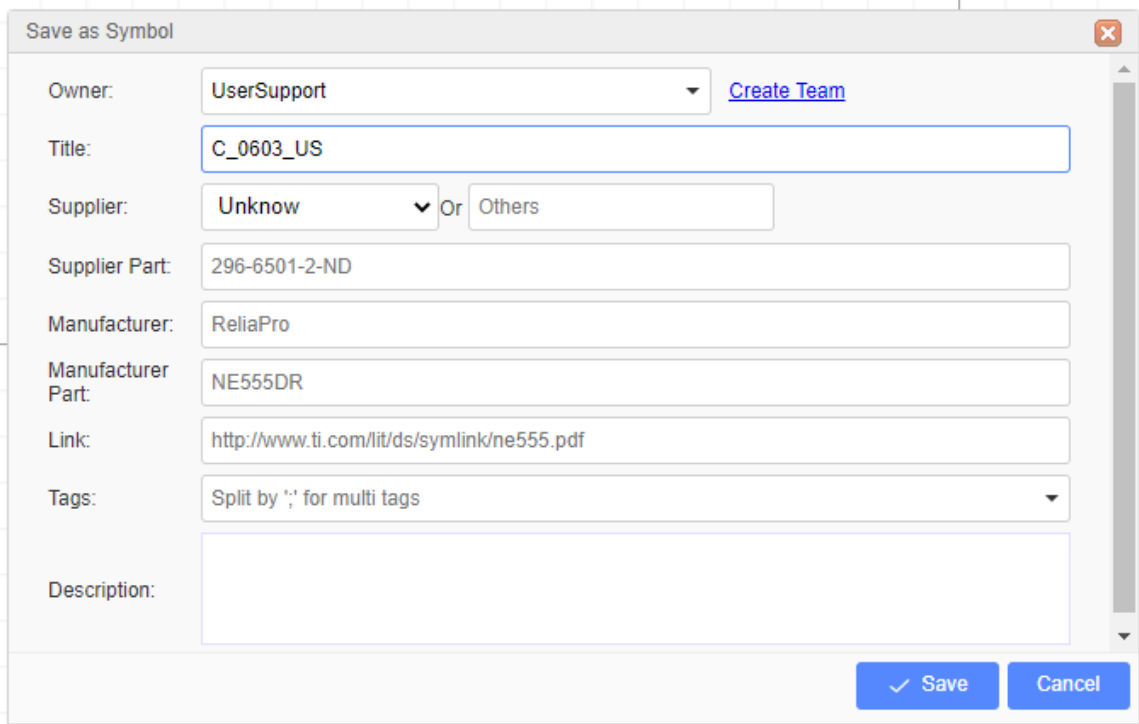

The 'Save as Symbol' dialog box contains the following fields:

- Owner: UserSupport (dropdown menu) with a [Create Team](#) link.
- Title: C_0603_US (text input)
- Supplier: Unknown (dropdown menu) with an 'Or' button and an 'Others' text input.
- Supplier Part: 296-6501-2-ND (text input)
- Manufacturer: ReliaPro (text input)
- Manufacturer Part: NE555DR (text input)
- Link: http://www.ti.com/lit/ds/symlink/ne555.pdf (text input)
- Tags: Split by ',' for multi tags (dropdown menu)
- Description: (empty text area)

Buttons at the bottom right: Save (with checkmark icon) and Cancel.

After finish, you can find your library at the left panel: **Library > Symbols > Work Space > All**

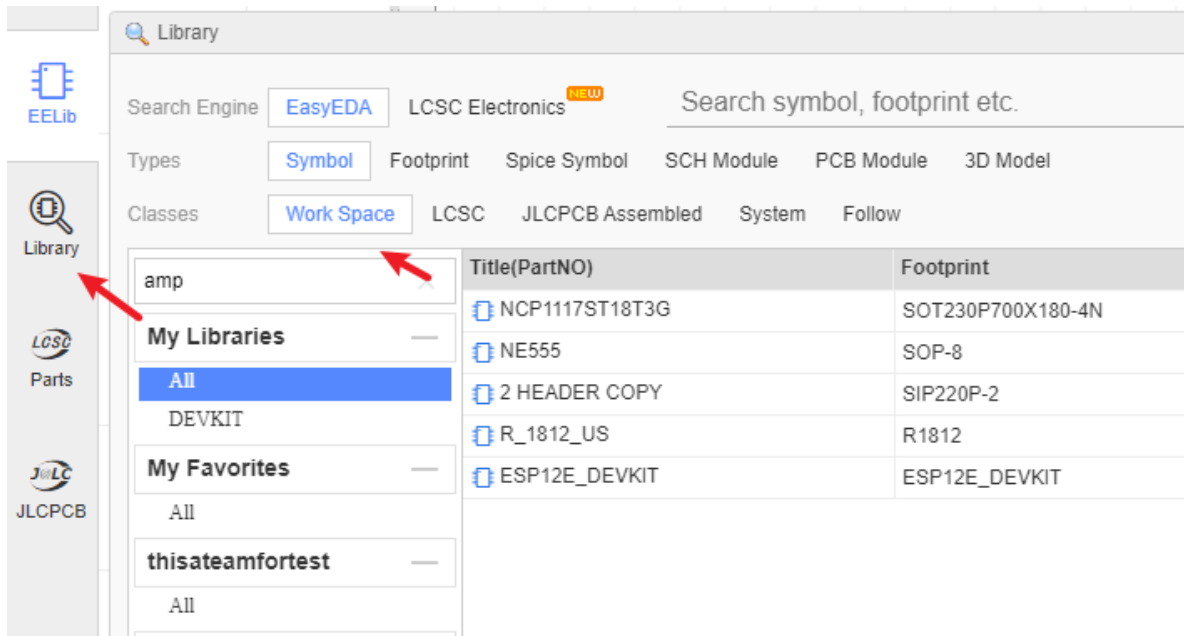

The Library panel shows a search engine (EasyEDA) and a search bar. Below are tabs for Types (Symbol, Footprint, Spice Symbol, SCH Module, PCB Module, 3D Model) and Classes (Work Space, LCSC, JLCPCB Assembled, System, Follow). A table lists symbols with their titles and footprints. A red arrow points to the 'amp' symbol in the table, and another red arrow points to the 'Library' icon in the left sidebar.

Title(PartNO)	Footprint
NCP1117ST18T3G	SOT230P700X180-4N
NE555	SOP-8
2 HEADER COPY	SIP220P-2
R_1812_US	R1812
ESP12E_DEVKIT	ESP12E_DEVKIT

Tag

When you select it , right-click it and select the menu "modify", you can add a tag for it.

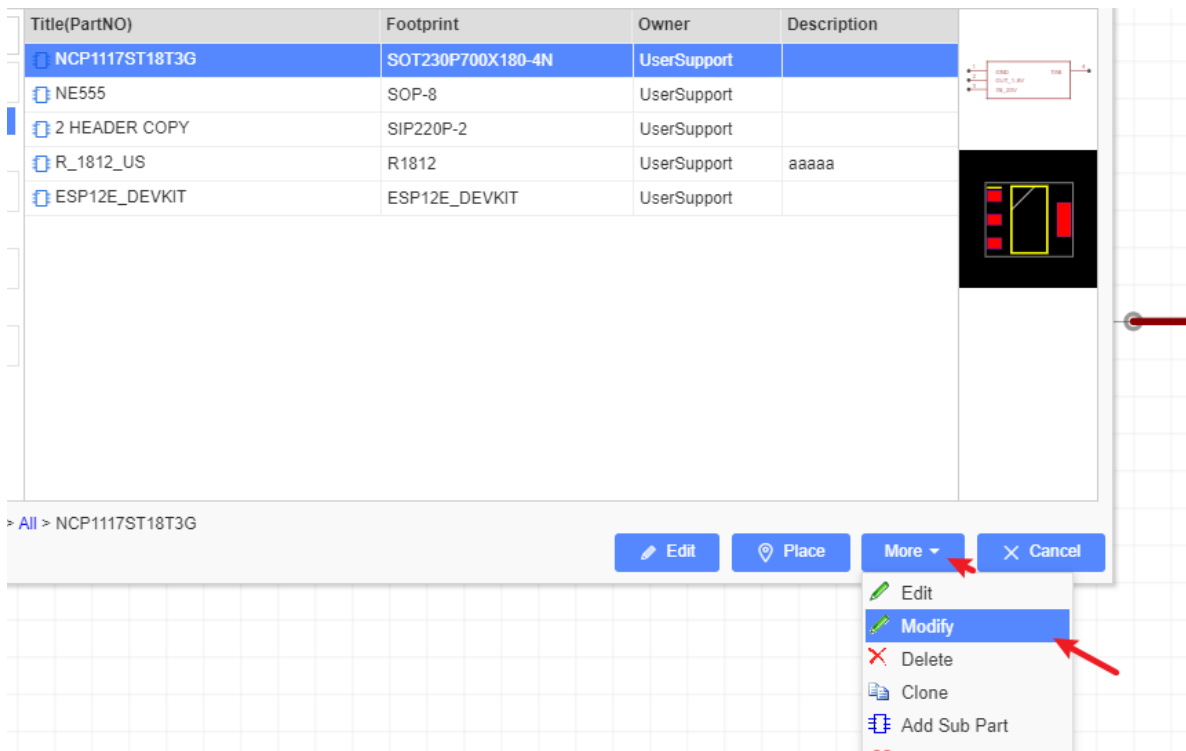

Favorite

When you favorite a library, you can find it at **Library > Symbols > Work Spacel > Favorite** , If this library has a tag, the tag will show up too, but you can't edit that. But you can via "Clone" or "Edit and save" to create a new library to personal libraries.

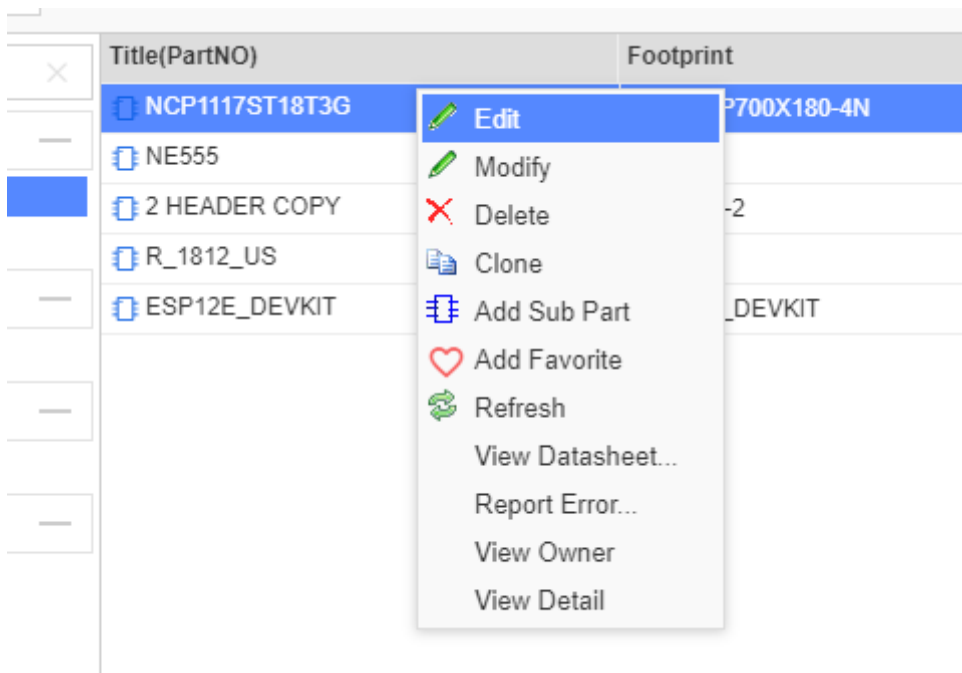

Edit Symbol in the Library

When you feel the Schematic Libs can not be satisfied for you, you can edit it.

Via **"Library" > "Search Part/Work Space/LCSC/System" > Select Symbol > Edit**

or you can click the preview image

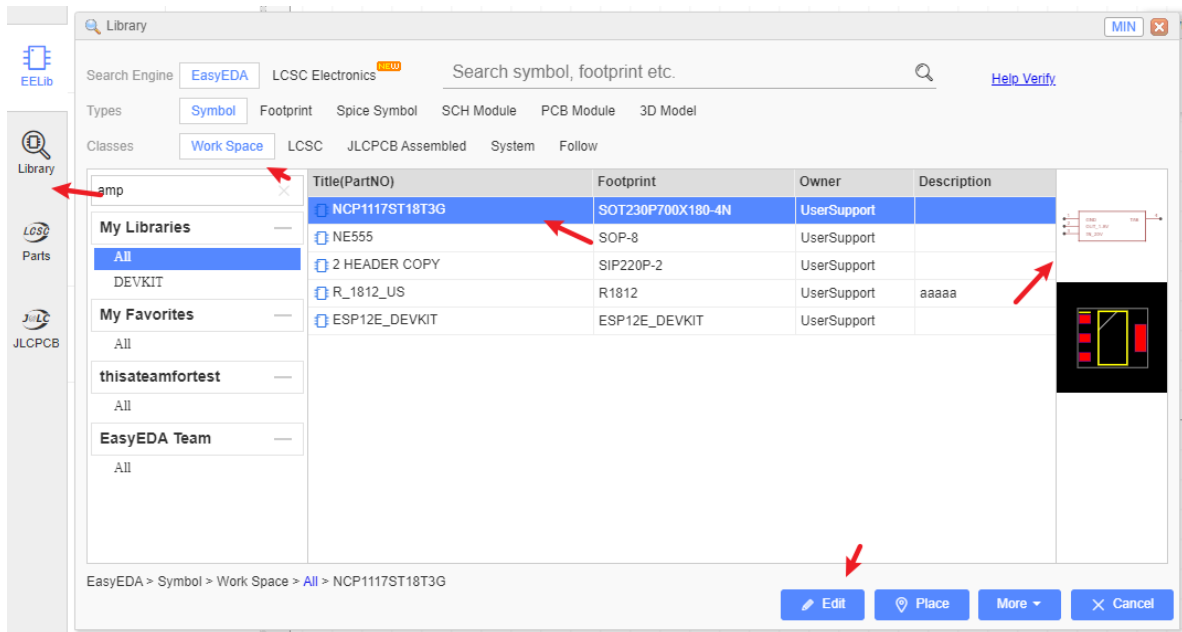

when you finish and save, it will be saved to your personal libraries **Work Space** and become your personal libraries.

Edit Symbol in the Schematic

If you want to edit a symbol in the schematic, you can use the Ungroup/Group function.

On the **Wiring Tools** palette there is the **Group/Ungroup Symbol...** button.

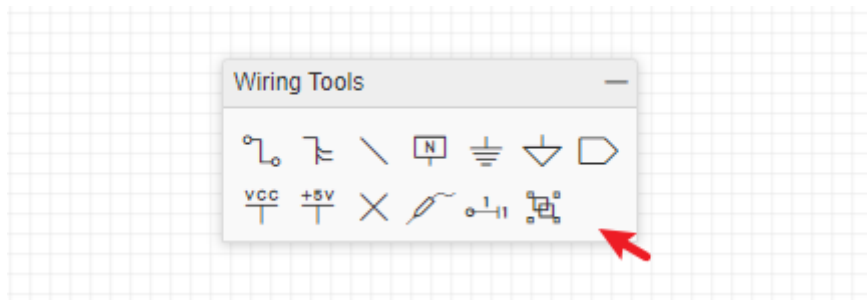

This tool is for you to quickly create or edit schematic library symbols.

1. Select a symbol
2. Click the **Group/Ungroup Symbol...** button
Up to this point you have a collection of separate pins, a drawn rectangle and some text that are all separate items with no particular association with each other.
3. Edit the shape or pin what you want to change
4. Select all of the items and click the **Group/Ungroup Symbol...** button.
A dialog will be opened:

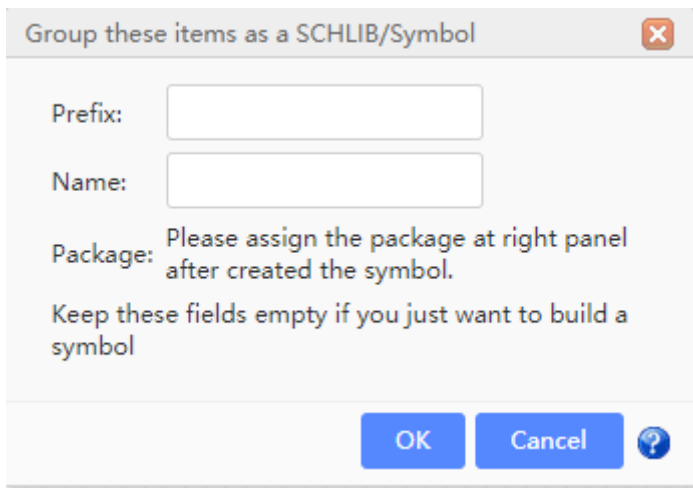

After you click OK, all those separate elements will be grouped together to form your new symbol directly in the schematic.

Using the group function, you can create/edit any symbol in the schematic, easily and quickly.

PCB Layout

Canvas Setting

After the initial conversion of a schematic to PCB, it is time to learn how to manage EasyEDA's PCB Design Editor.

Canvas Attributes

Lots of PCB canvas attributes are the same as Schematic canvas attributes. The key is that you can set **units** in PCB canvas attributes.