

Bahan Ajar

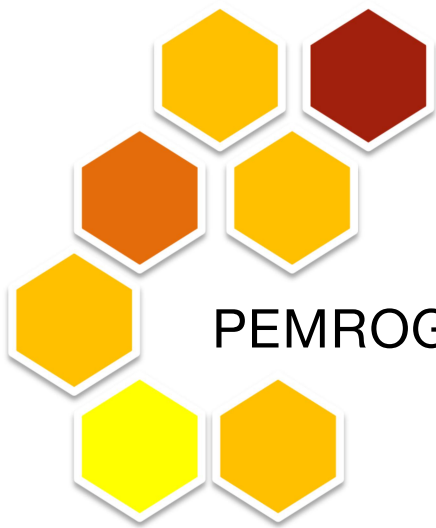

Modul

PEMROGRAMAN TERSTRUKTUR

Kode Matakuliah: SKO20411

C For Arduino

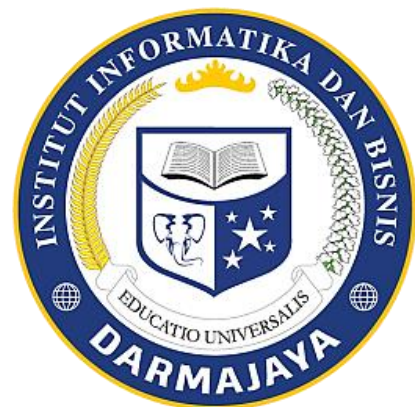

Penyusun:
Bayu Nugroho. S.Kom., M.Eng

**PROGRAM STUDI SISTEM KOMPUTER
FAKULTAS ILMU KOMPUTER
INSTITUT INFORMATIKA DAN BISNIS DARMAJAYA**

2022

DAFTAR ISI

Halaman Judul	1
Daftar Isi	2
I. INTRODUCTION (PEMROGRAMAN TERSTRUKTUR)	3
1. Bahasa Pemrograman C	3
2. Bahasa C for Arduino	4
3. Instalasi Arduino IDE	5
4. Struktur Program C Arduino	6
5. Instalasi Simulator Software	9
JOBSHEET 1 & 2	9
II. JOBSHEET 3	
Tipe Data for C Arduino (Blinking LED)	10
III. JOBSHEET 4	
Konstanta dan Variable (Motor Spin)	12
IV. JOBSHEET 5	
Decision IF-ELSE (Servo)	15
V. JOBSHEET 6	
Precedence of Operator C for Arduino (Buzzer)	17
VI. JOBSHEET 7	
Looping Program in C Arduino (LED)	20
VII. JOBSHEET 8	
Function in C Arduino (Pushbuttons).....	22
VIII. JOBSHEET 9	
Logical Operators (LDR)	24
IX. JOBSHEET 11	
Storage Classes and Scope (TMP36)	26
X. JOBSHEET 11	
Pointer and Array 1 Dimensi (LED)	29
XI. JOBSHEET 12	
Pointer and Array Multi Dimensi (LED)	31
XII. JOBSHEET 13	
Matrix (8x8)	34
XIII. JOBSHEET 14	
Bitwise Operations in C Arduino	39

JOB SHEET 11

Storage Classes and Scope (TMP36)

KOMPONEN

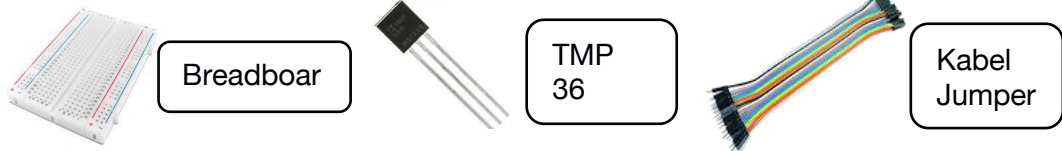

SKEMA

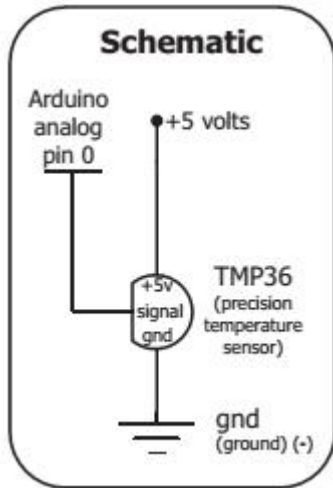

PERAKITAN

Hubungkan Pin analog 0 Arduino ke kaki Sensor pada papan breadboard dan pin tegangan dan pin ground seperti pada gambar.

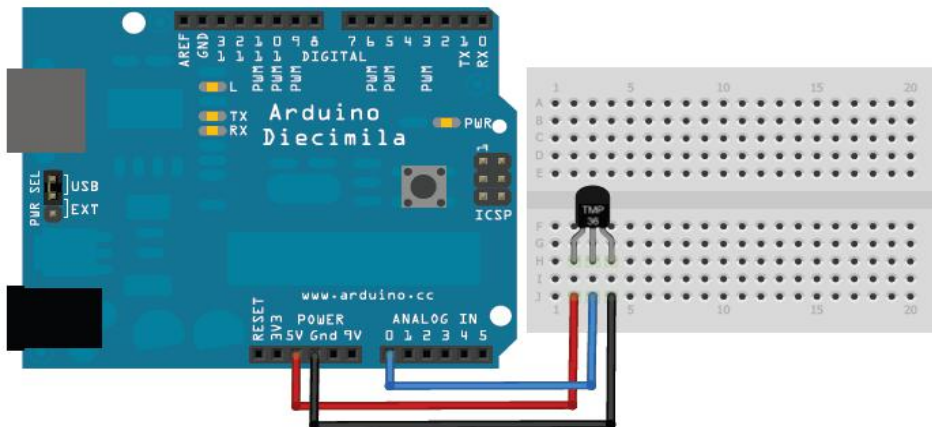

KODE PROGRAM

```
/* -----
 * A simple program to output the current temperature
 * to the IDE's debug window
 * -----
 */

//TMP36 Pin Variables
int temperaturePin = 0;
//the analog pin the TMP36's
//Vout pin is connected to
//the resolution is
//10 mV / degree centigrade
//(500 mV offset) to make
//negative temperatures an option

void setup()
{
  Serial.begin(9600); //Start the serial connection
  //with the computer
  //to view the result open the
  //serial monitor
  //last button beneath the file
  //bar (looks like a box with an
  //antenna)
}

void loop()
// run over and over again
{
  float temperature = getVoltage(temperaturePin);
  //getting the voltage reading from the

  //temperature sensor
  temperature = (temperature - .5) * 100;
  //converting from 10mv
  //per degree wit 500 mV offset to
  //degrees ((voltage - 500mV) times 100)
  Serial.println(temperature); //printing the result
  delay(1000); //waiting a second

}

/*
 * getVoltage() - returns the voltage on the analog input
 * defined by pin
 */

float getVoltage(int pin) {
  return (analogRead(pin) * .004882814); //converting from a 0
  //to 1024 digital range
  // to 0 to 5 volts
  //(each 1 reading equals ~ 5 millivolts
}
```

LATIHAN

Lakukan memprogram penyimpanan hasil sensor TMP36 dalam bahasa C for Arduino.

LAPORAN HASIL PERCOBAAN: