

MATERIAL KAYU

LAPIS & PENUNJANG



KEMAMPUAN AKHIR YANG DIHARAPKAN

- Mahasiswa mampu mengevaluasi material kayu lapis dan penunjang yang cocok untuk digunakan dalam proyek konstruksi furnitur sederhana.



MULTIPLEKS

- Minimum terdiri dari 3 lapis yang bersilangan.
- Ketebalan : 3, 4, 6, 9, 12, 15, 18 mm.
- Ukuran papan : 122 x 244 cm.
- Permukaan lembaran dapat dilapis dengan :
 - Finir (*Veneer*)
 - Formika/HPL
 - Kain
 - PVC/Plastik
 - Metal
- Bagian sisi tebalnya sebaiknya ditutup juga supaya pengaruh air pada sisi ini dapat dikurangi.



MULTIPLEKS

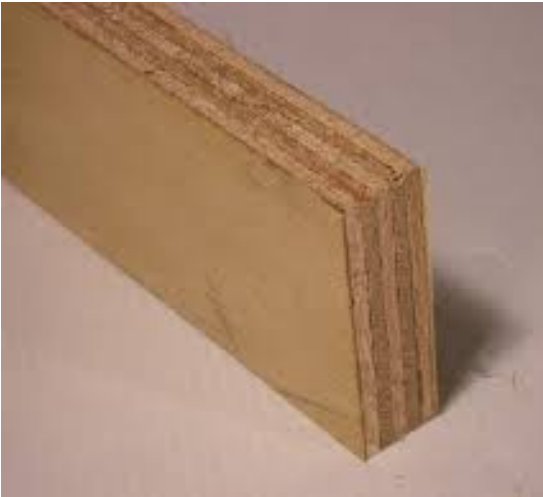
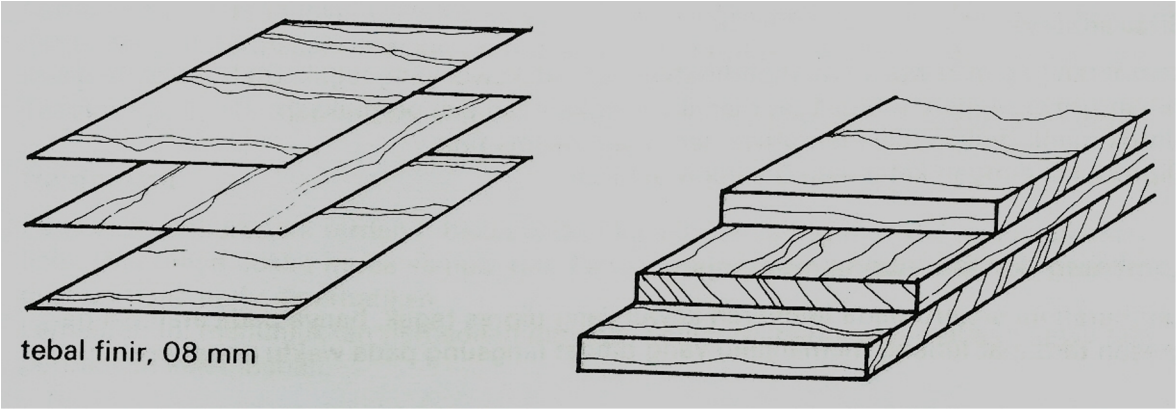

PELAPIS : FINIR (VENEER)

- Sayatan lembaran kayu yang tipis.
- Menurut penggunaannya :
 - Finir Pengikat (tebal $\pm 1,2 - 3,6$ mm).
Menghindarkan kembang susutnya tripleks.
 - Finir Bawah (tebal 0,9 mm).
Menghindarkan pecah-pecahnya finir penutup.
 - Finir Penutup (tebal 0.6 – 3 mm).
Memperbaiki permukaan lembaran yang difinir.
 - Finir Pelawan (tebalnya = Finir Penutup).
Memperbaiki permukaan lembaran yang akan melengkung karena finir penutup.



PELAPIS : FINIR (VENEER)

- Menurut cara pembuatan :
 - Finir Kupasan, dibuat dengan mengupas batang.
 - Finir Sayatan, dikerjakan seperti mengetam (serut).
 - Finir Belah, dihasilkan dengan gergaji (jarang dilakukan, meninggalkan sisa & makan waktu).
 - Finir Radial, pada prinsipnya dikerjakan seperti meraut pensil.



PELAPIS : FORMIKA/HPL

- Disebut juga “Formika”, sesuai dengan nama pabrik yang pertama membuatnya.
- Bahan pokok : kertas selulosa yang dicelup dalam damar sintetis (melamin, phenol, dsb).
- Lembaran sintetis terdiri dari susunan kertas yang dipres.



HARDWARE / AKSESORIS



HANDLE

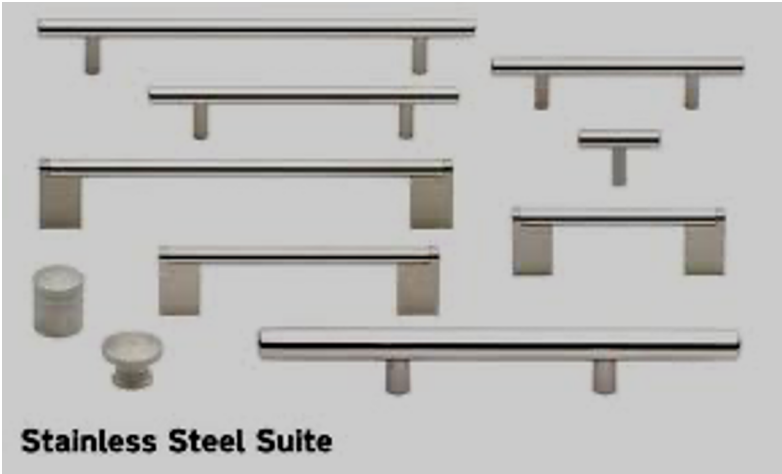

ENGSEL



Engsel
Rp. 1.300 /pcs



Engsel Premium
90degr Rp. 2.600 /pcs



Engsel klip 170degr
Rp. 8.000/pcs



Touch latch
Rp. 14.000



Engsel klip (soft close)



Mini spring
Rp. 6.500/pcs



Stickon Damper
Rp.10.000/100pcs



Mata Bor obeng
Rp. 25.000/10pcs

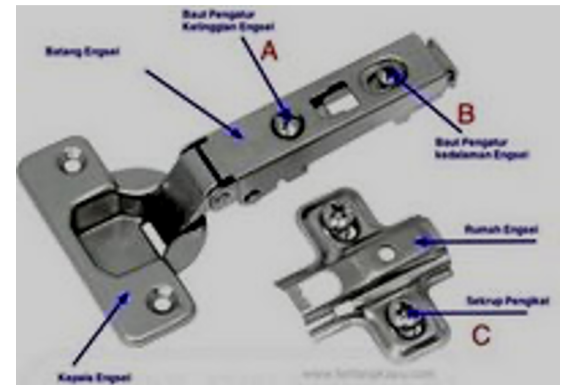
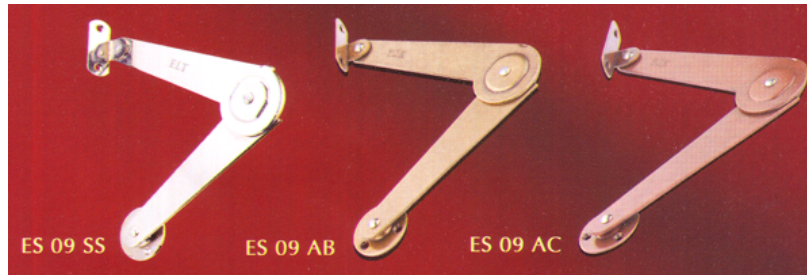
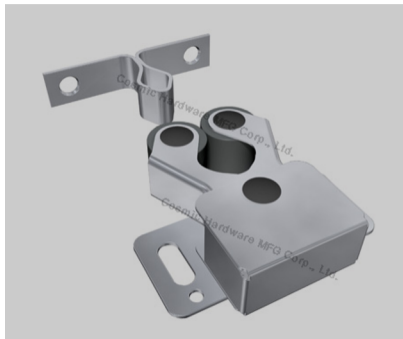

REL (LACI & LEMARI)

